



# Bücker Bu133 "Jungmeister"

1 / 3 s c a l e R C



P H O T O M A N U A L









## 1. FUSELAGE

### NOTE:

The pictures are of the prototype.  
In the serial production we can have made  
some improvements.

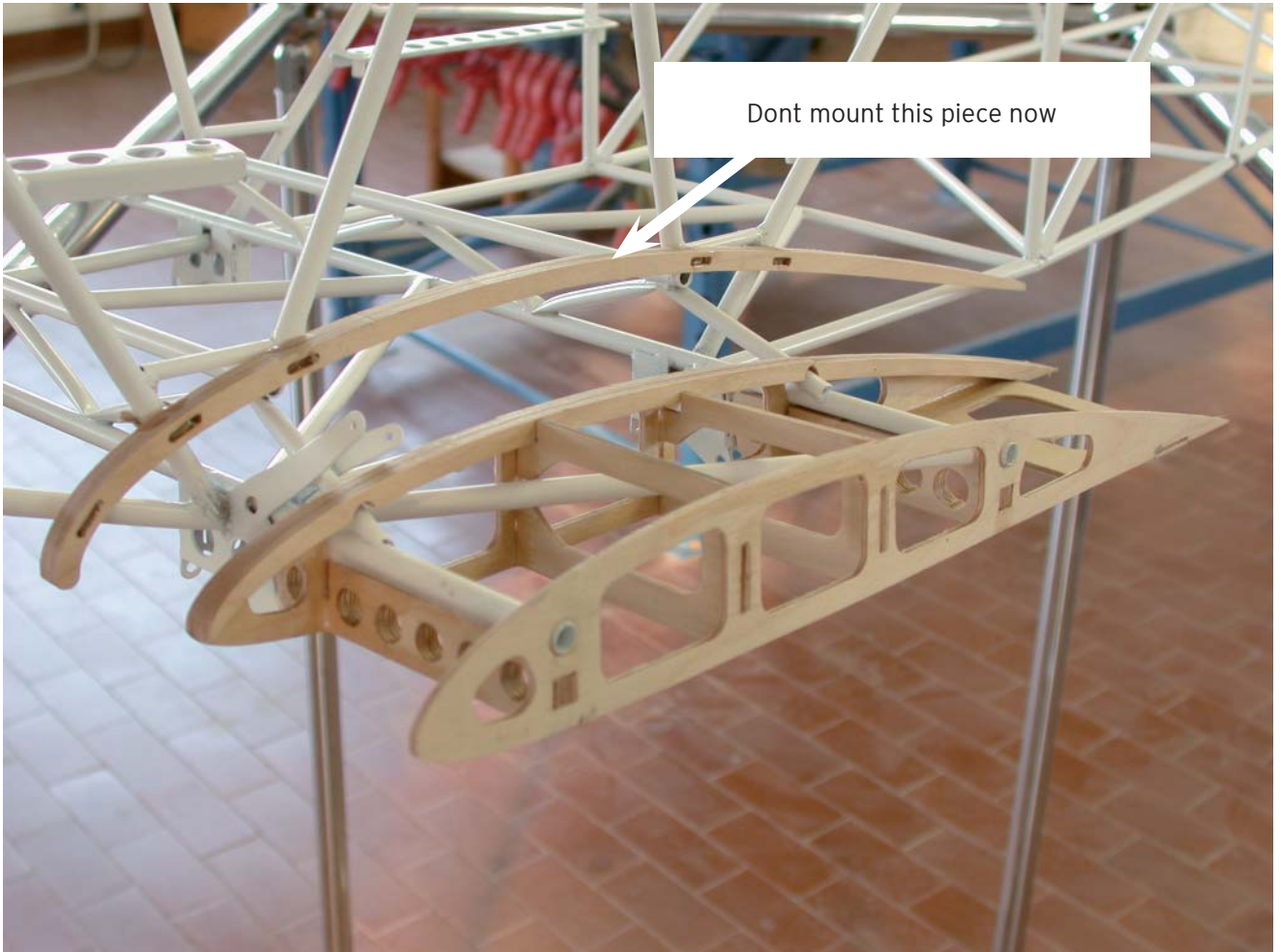
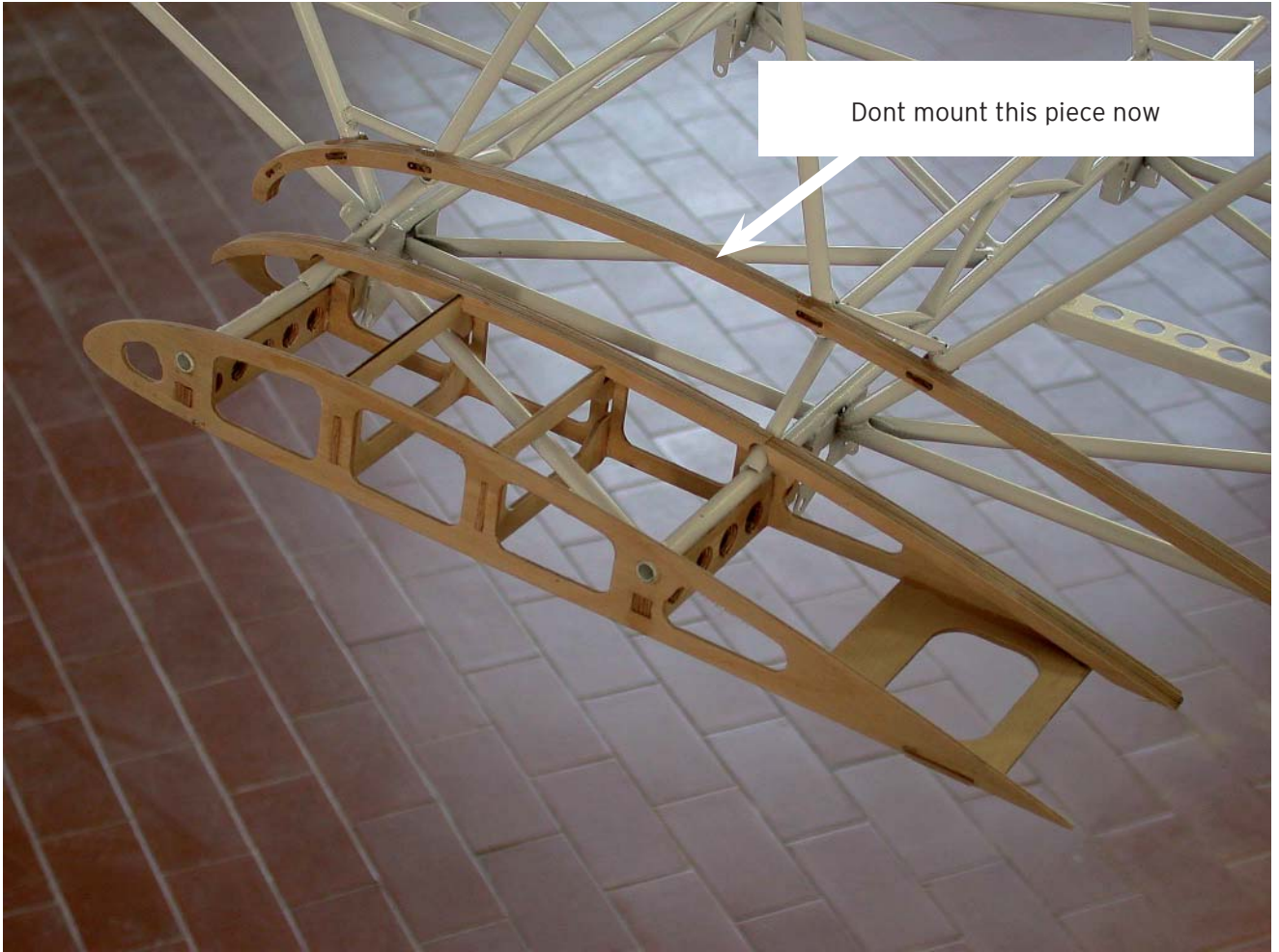



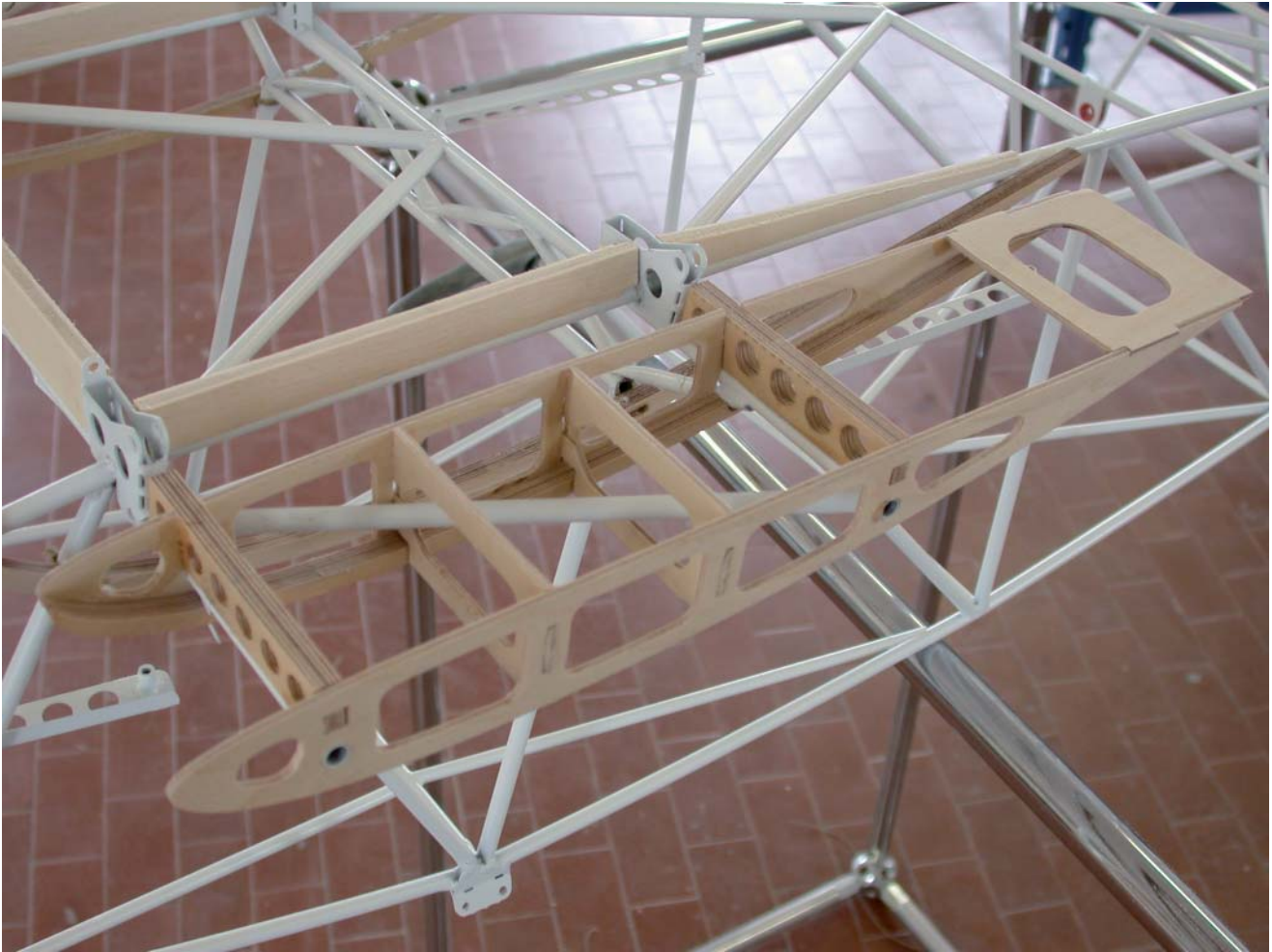



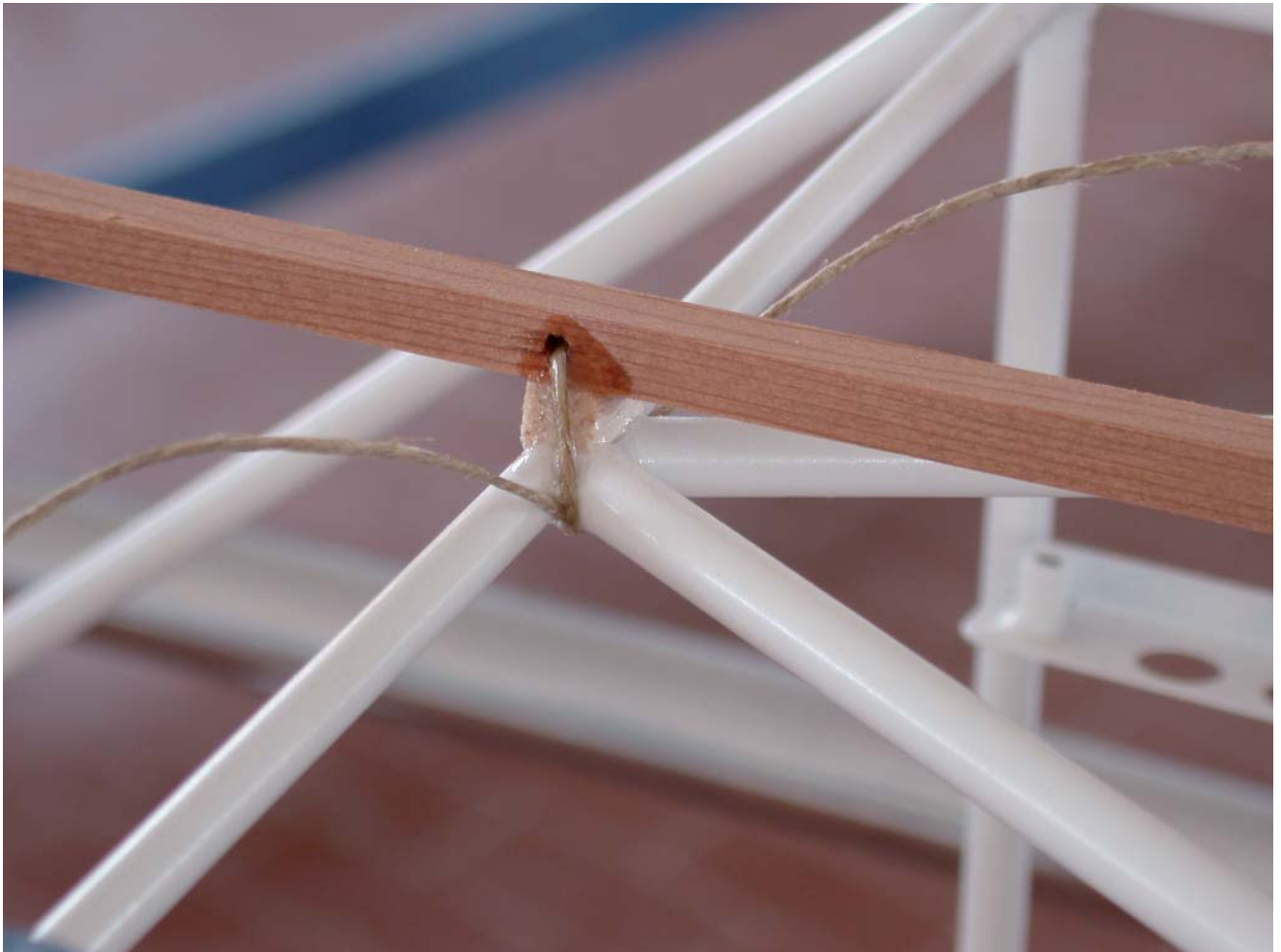
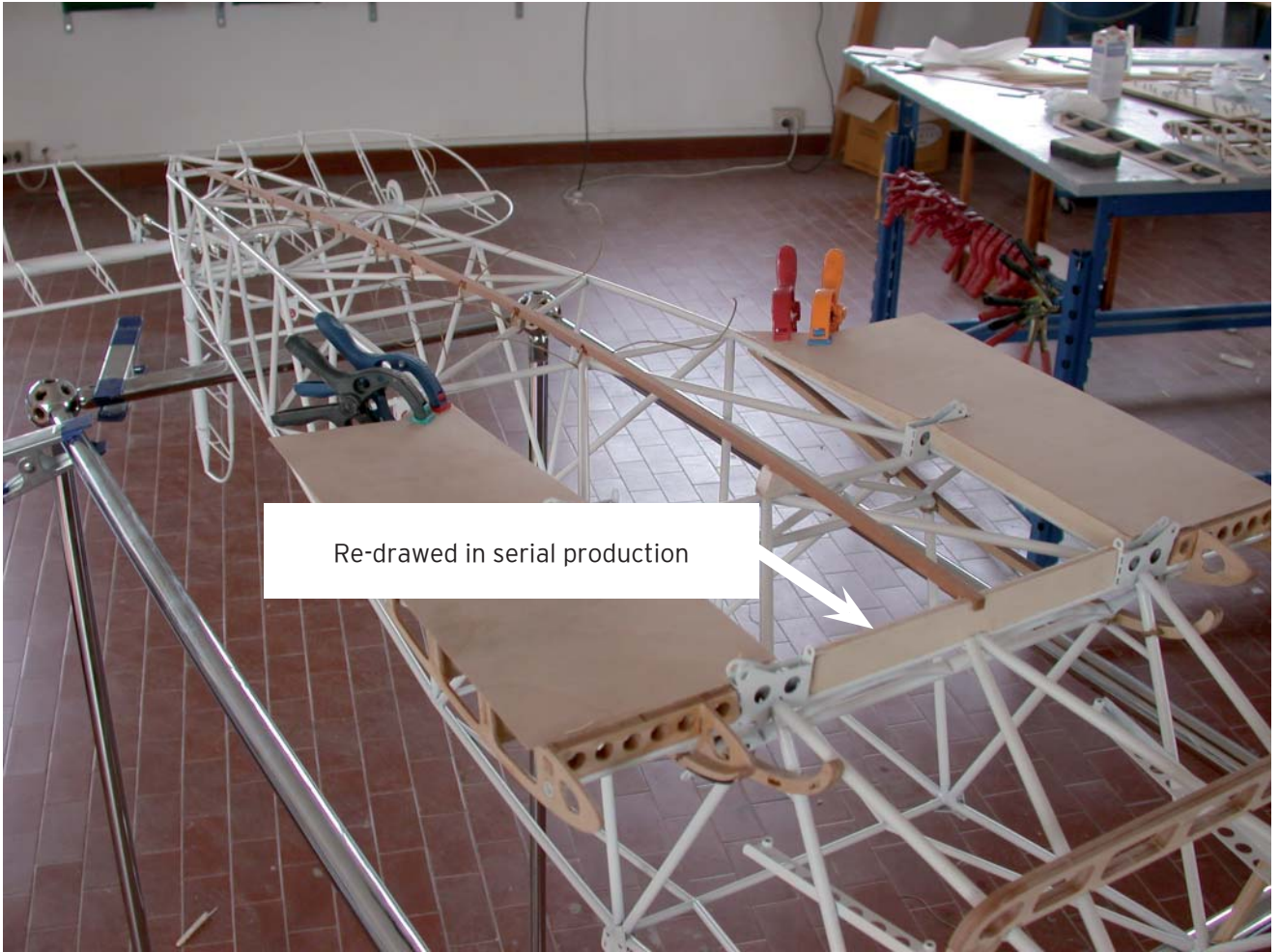







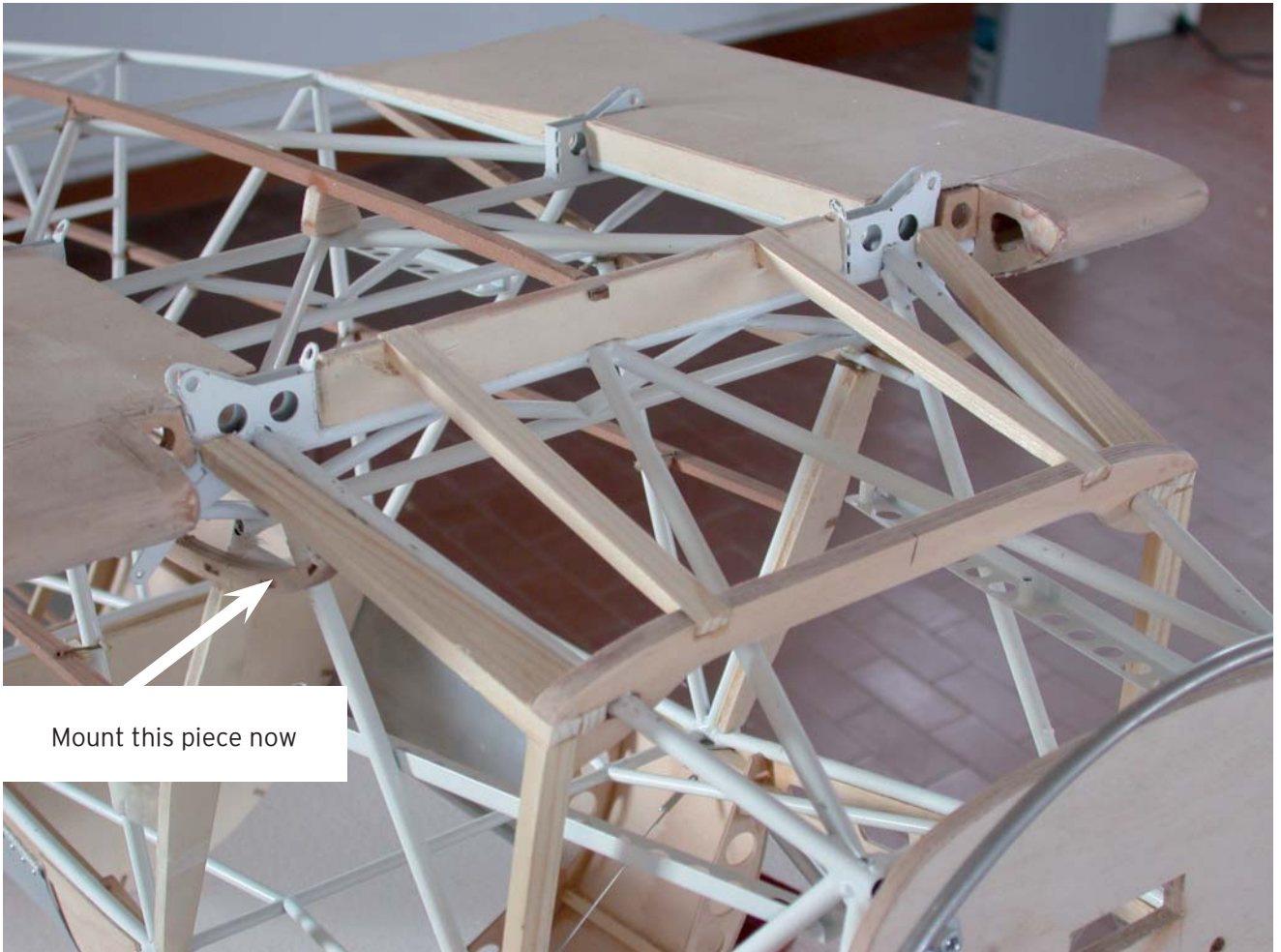
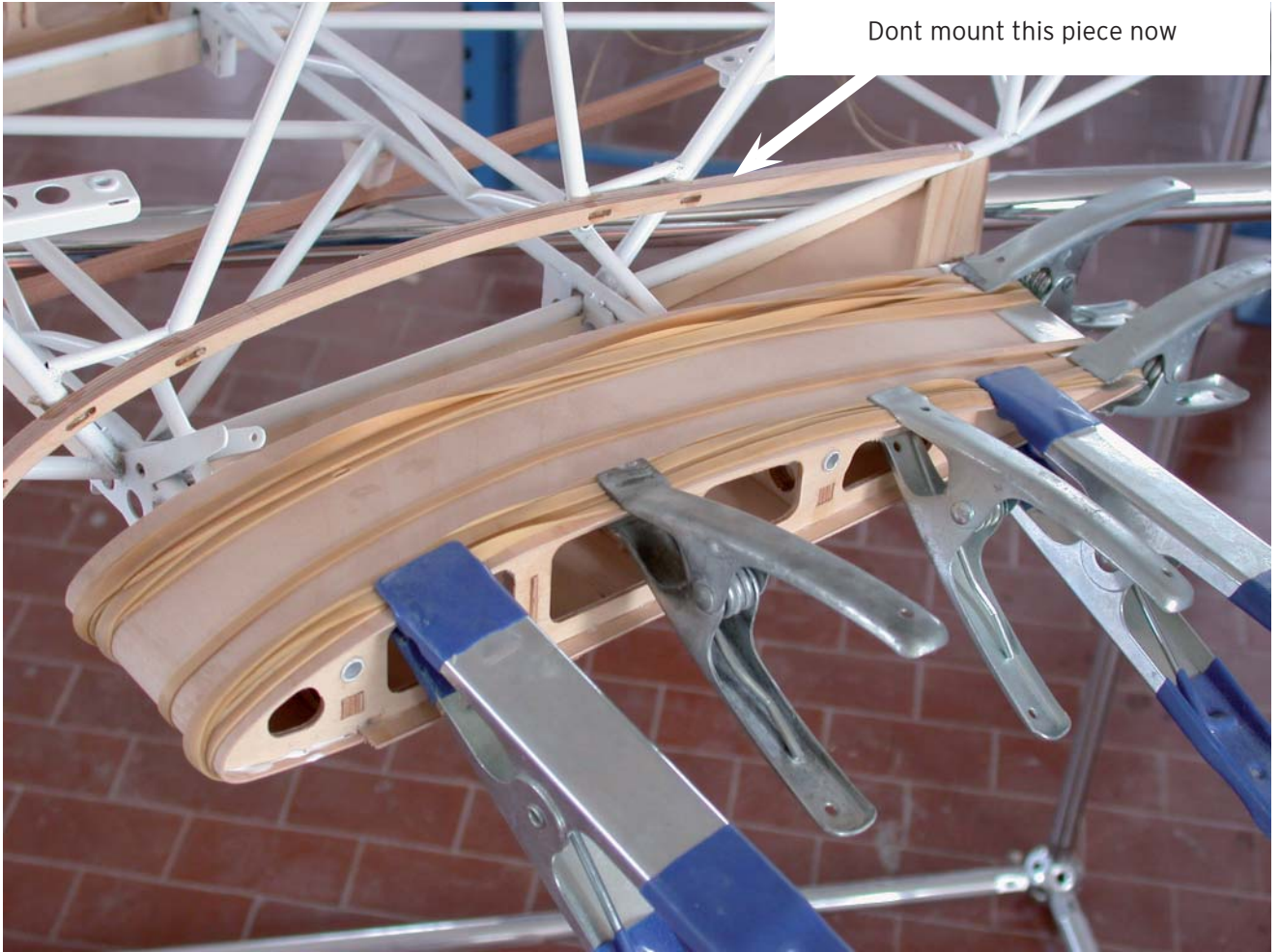



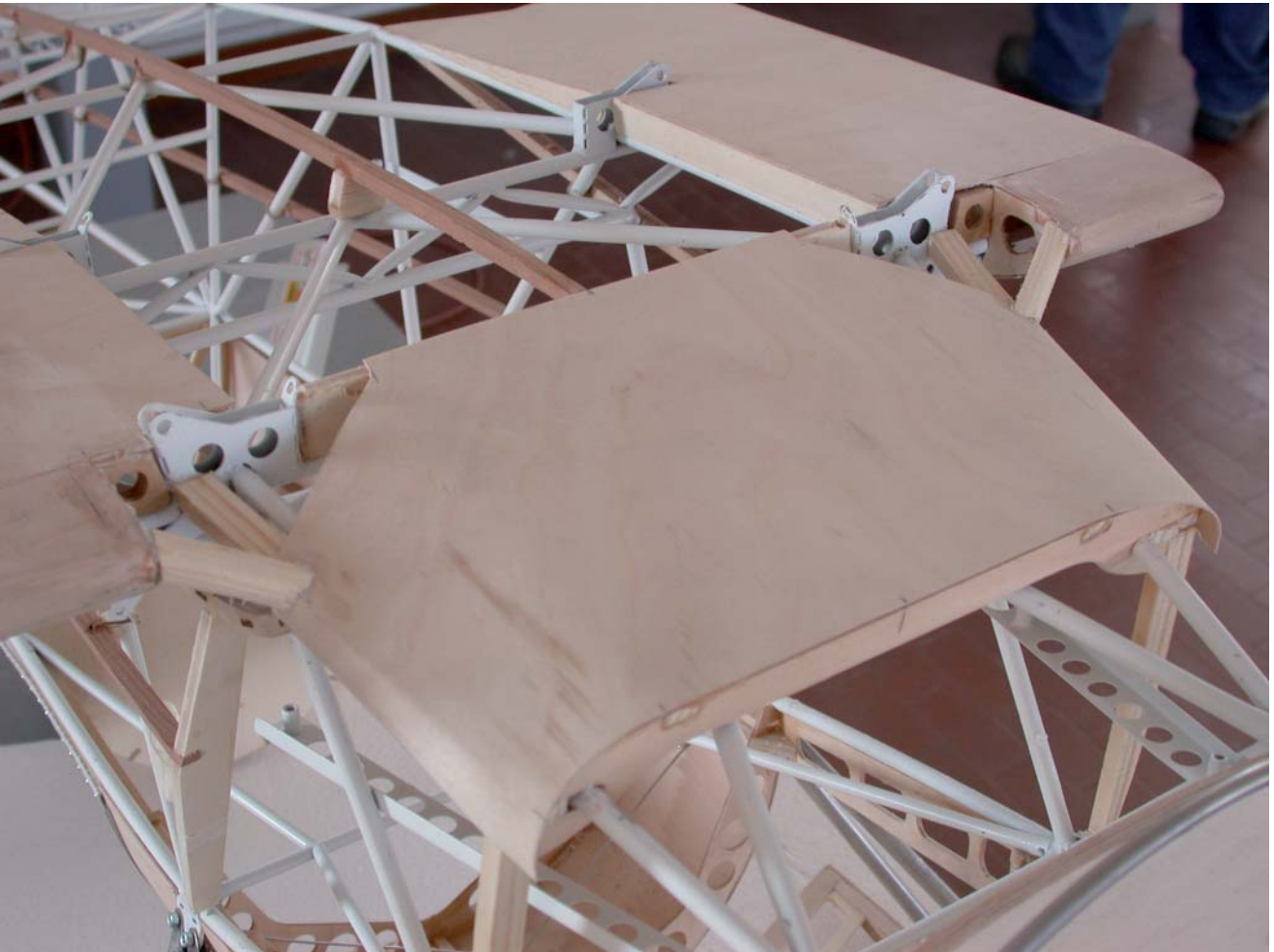

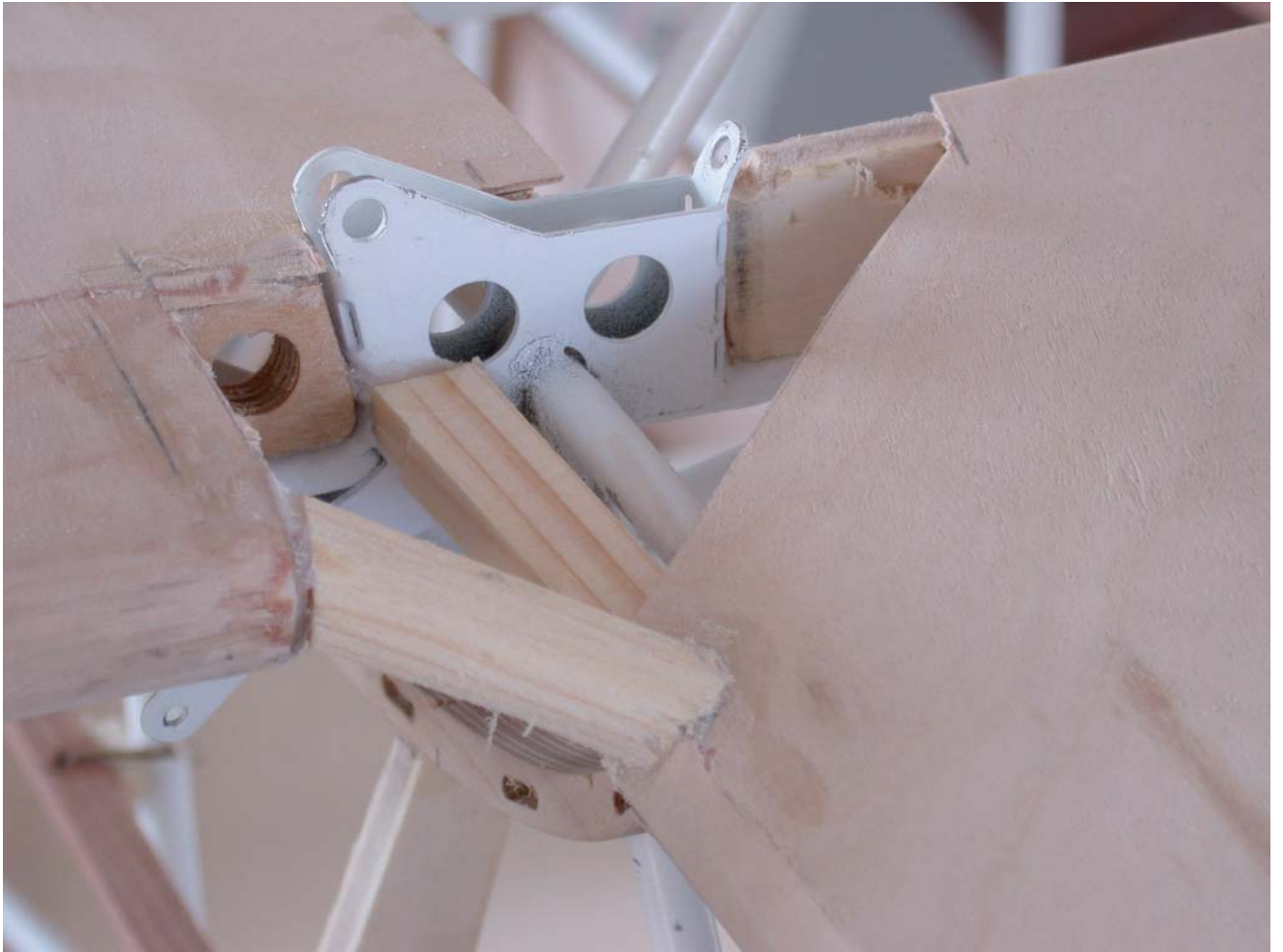



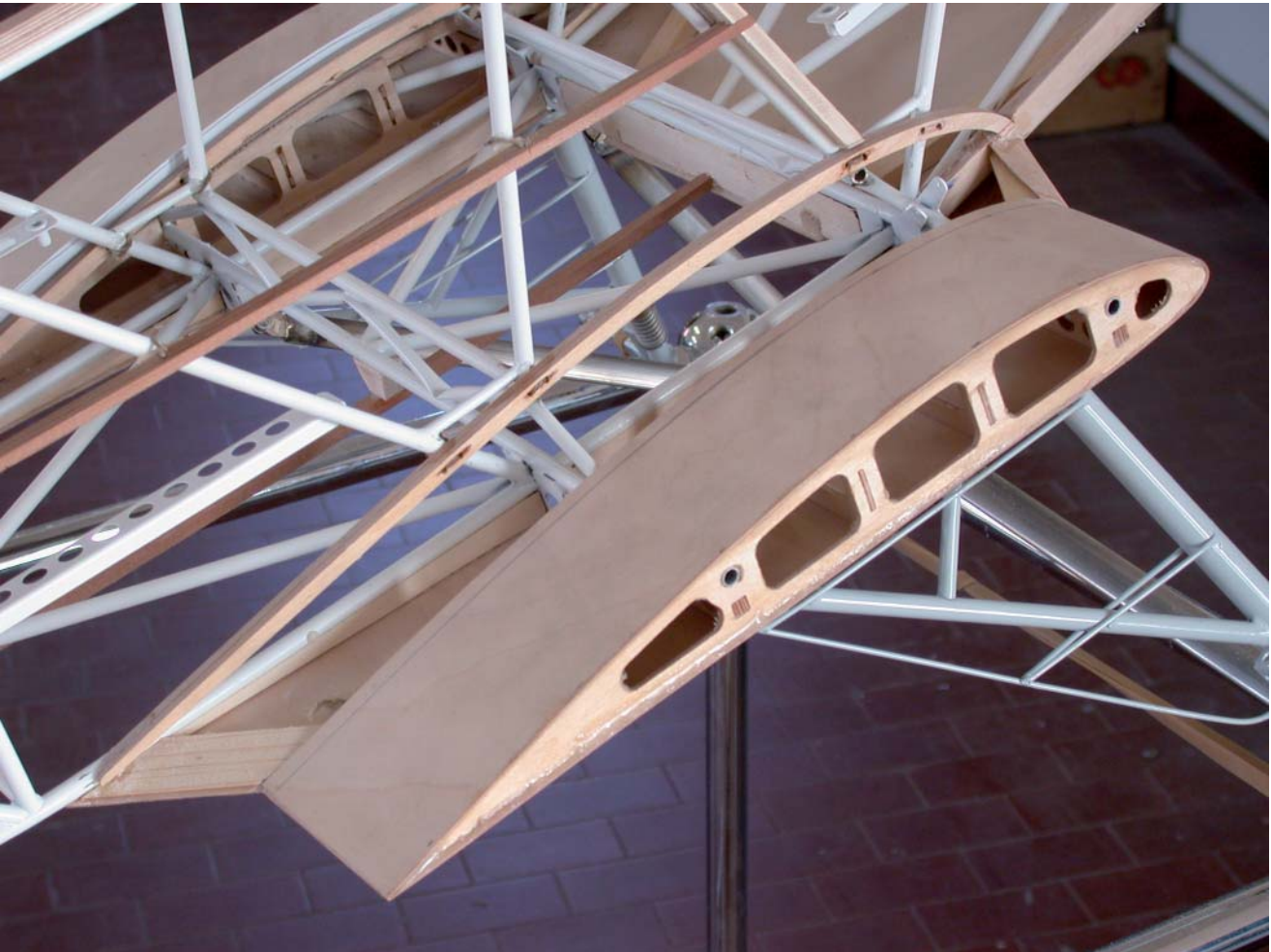







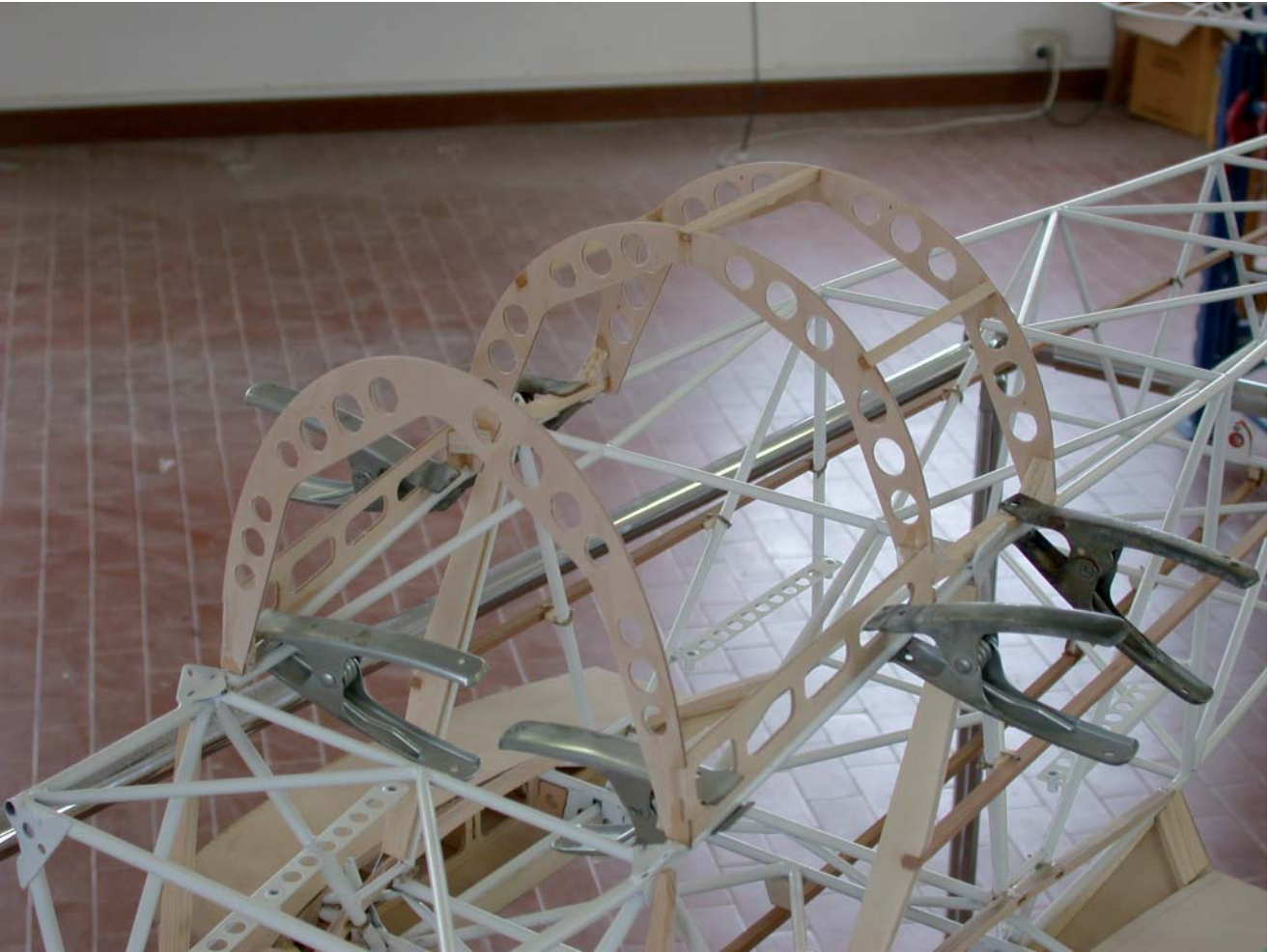







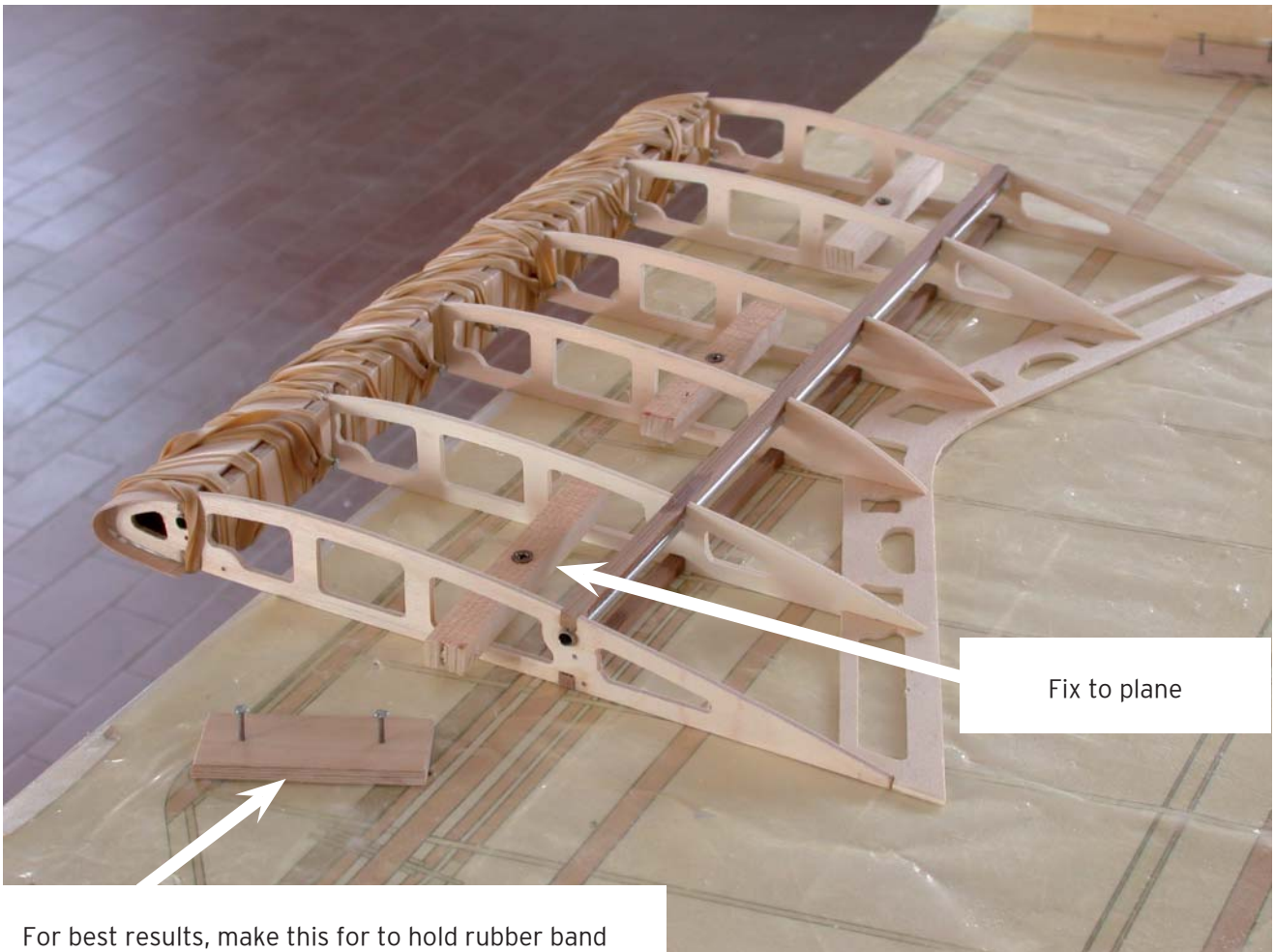
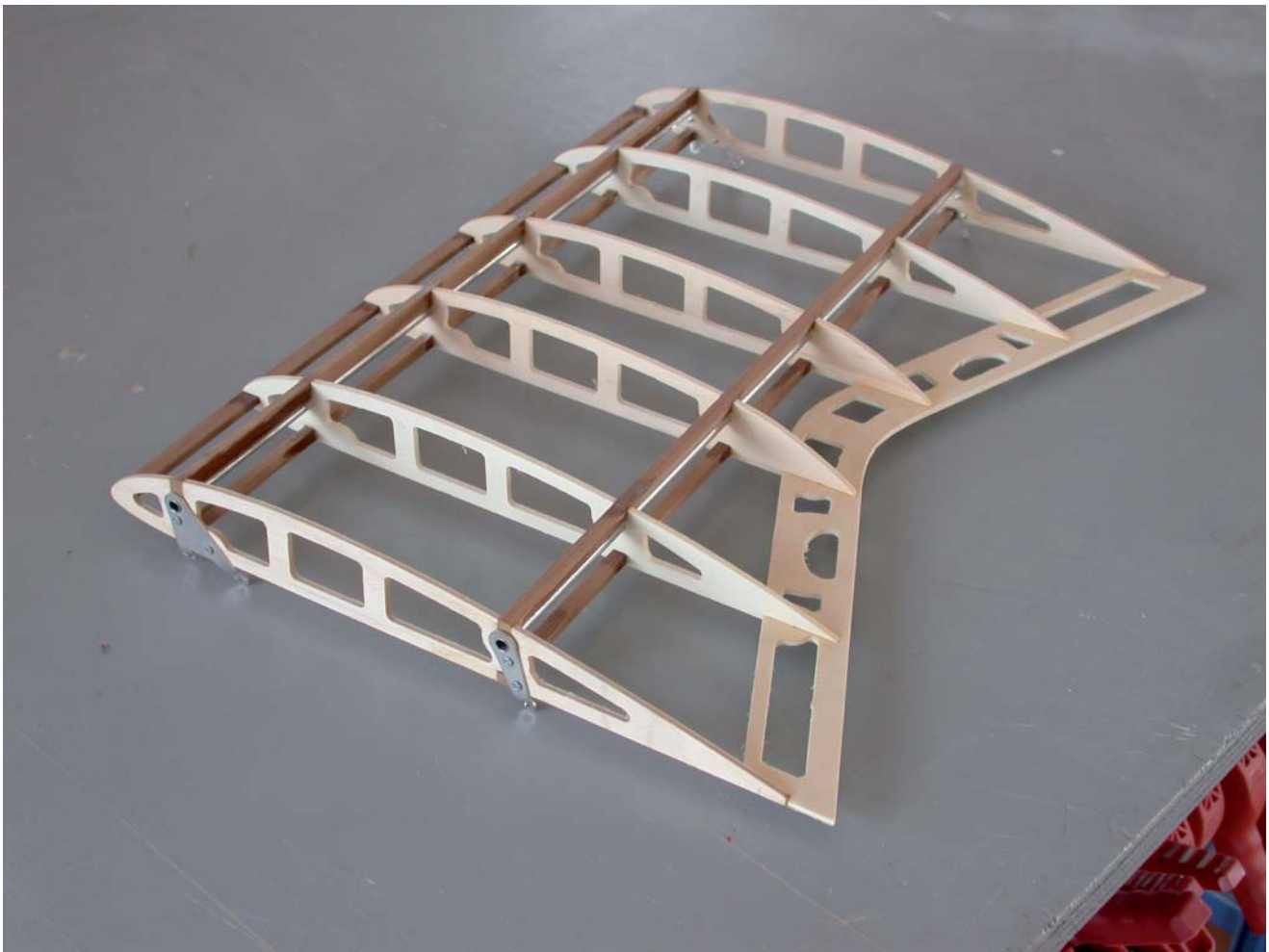

For best results, make this for to hold rubber band



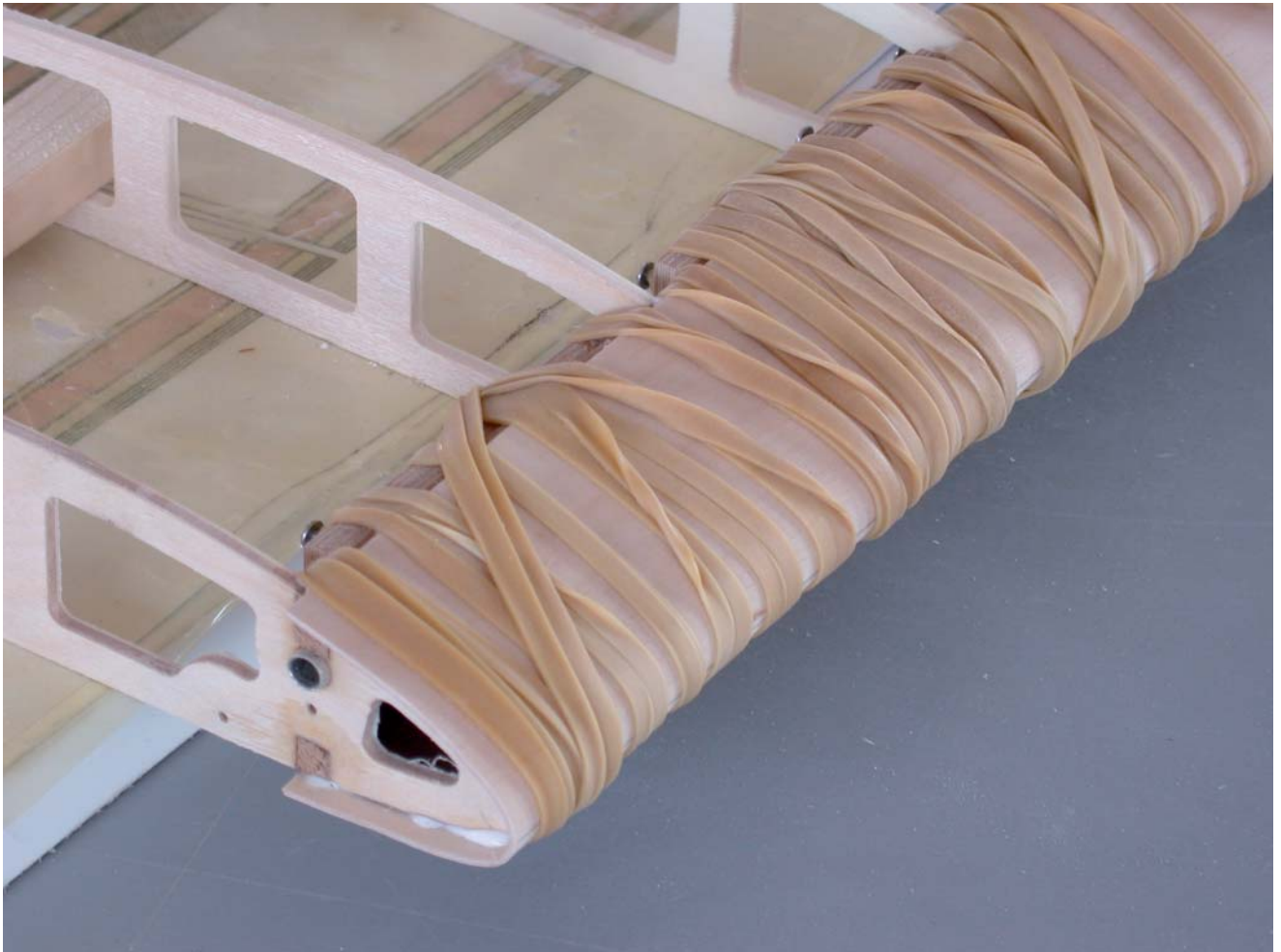
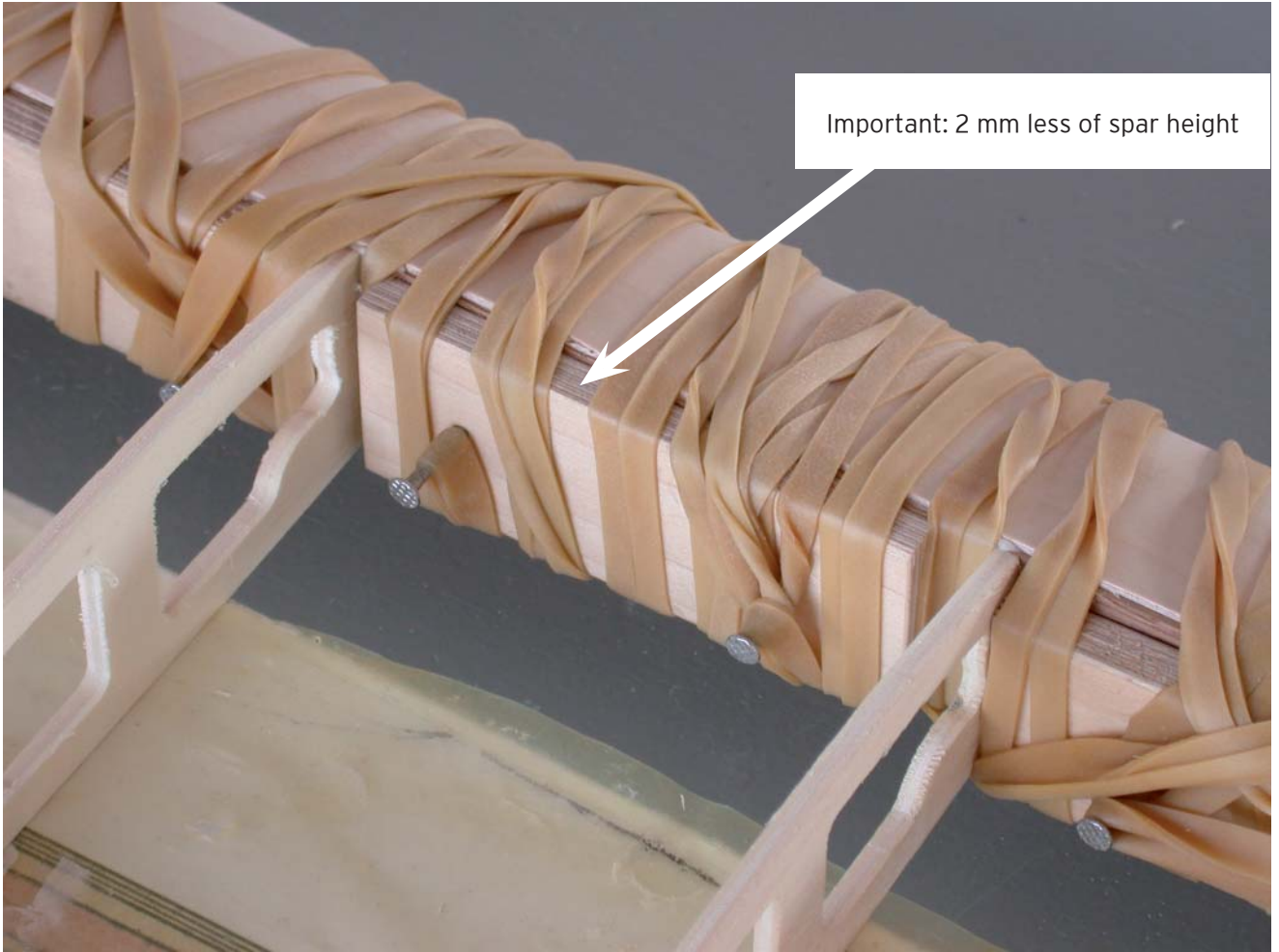



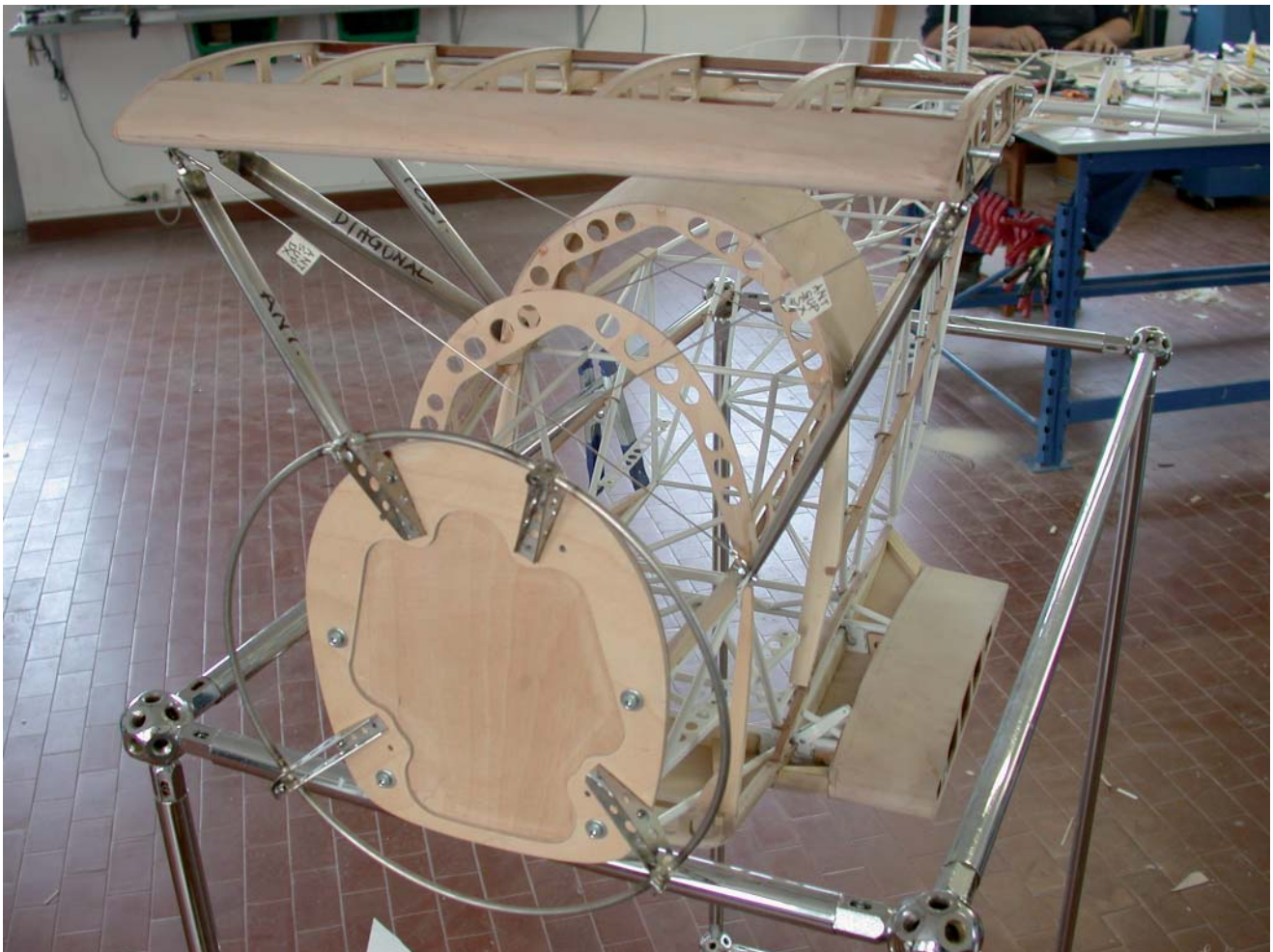







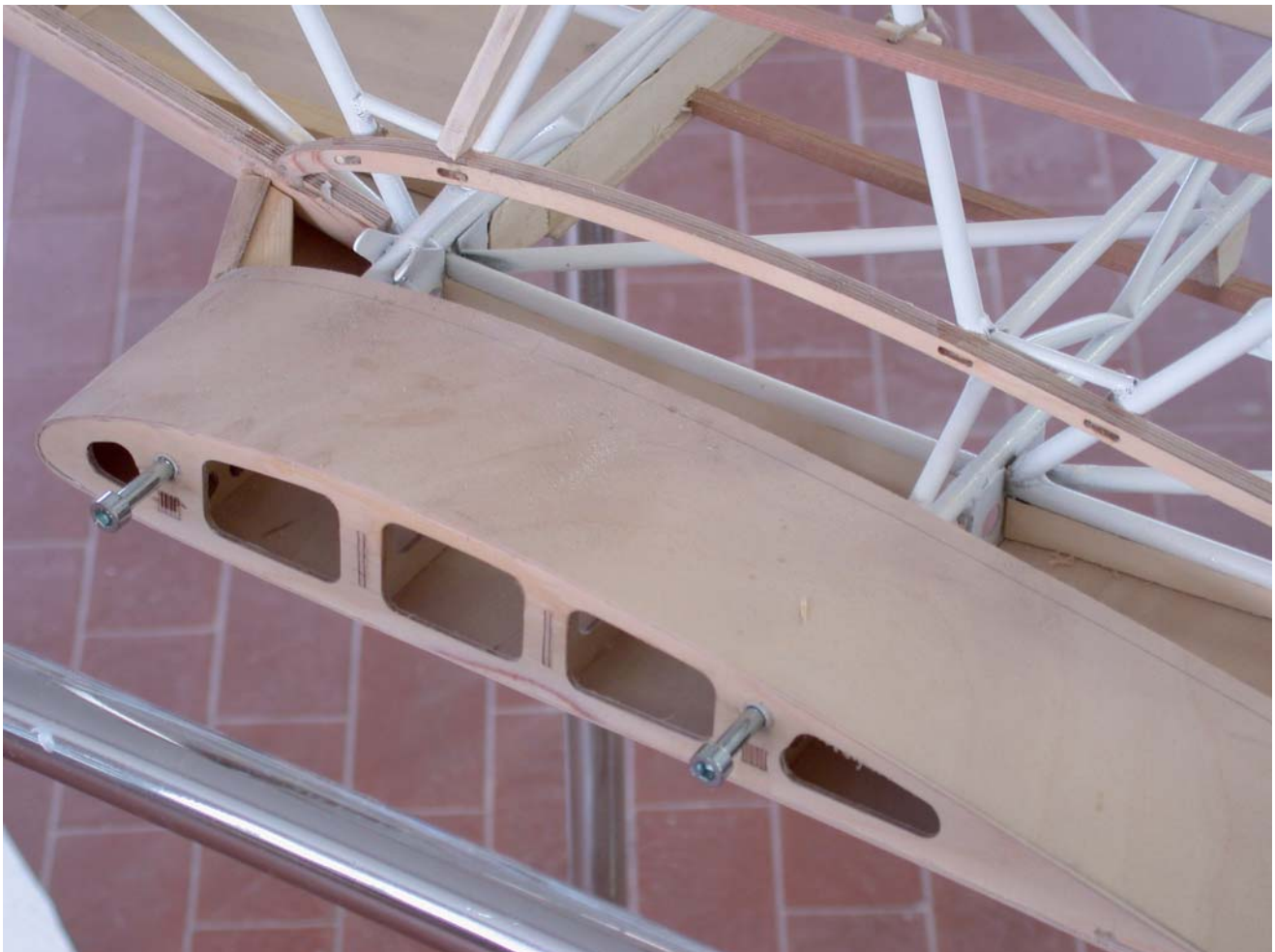



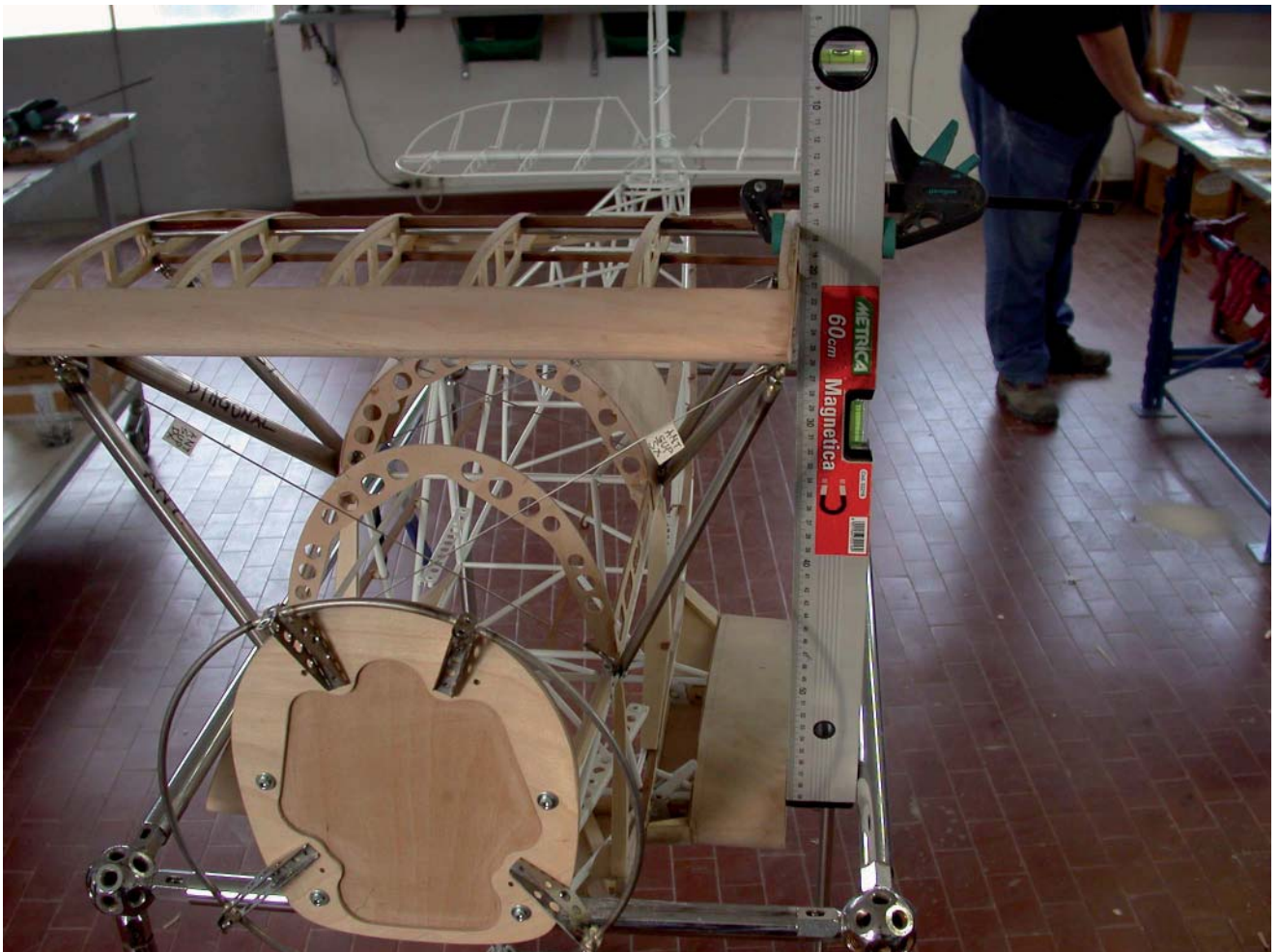
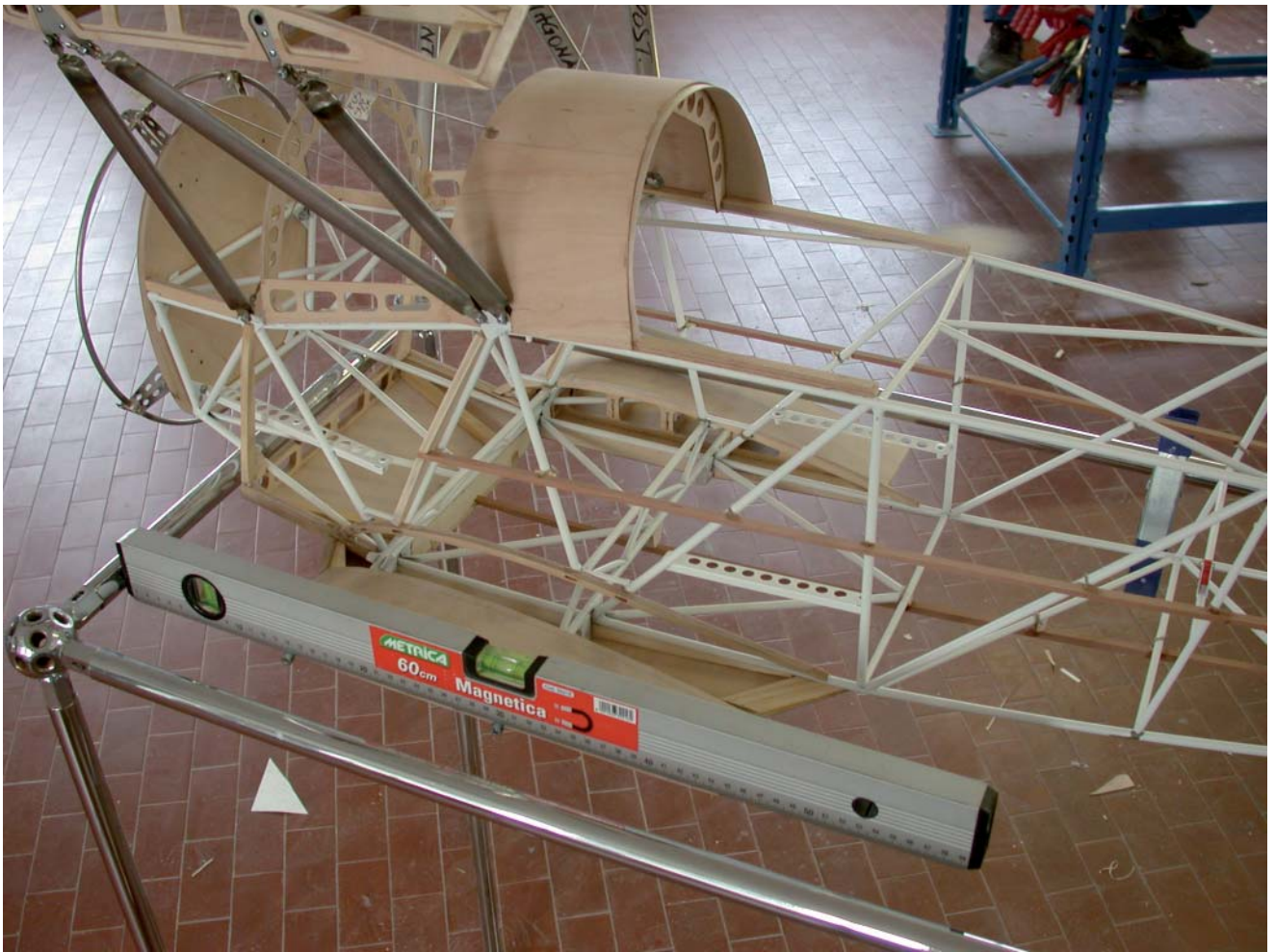





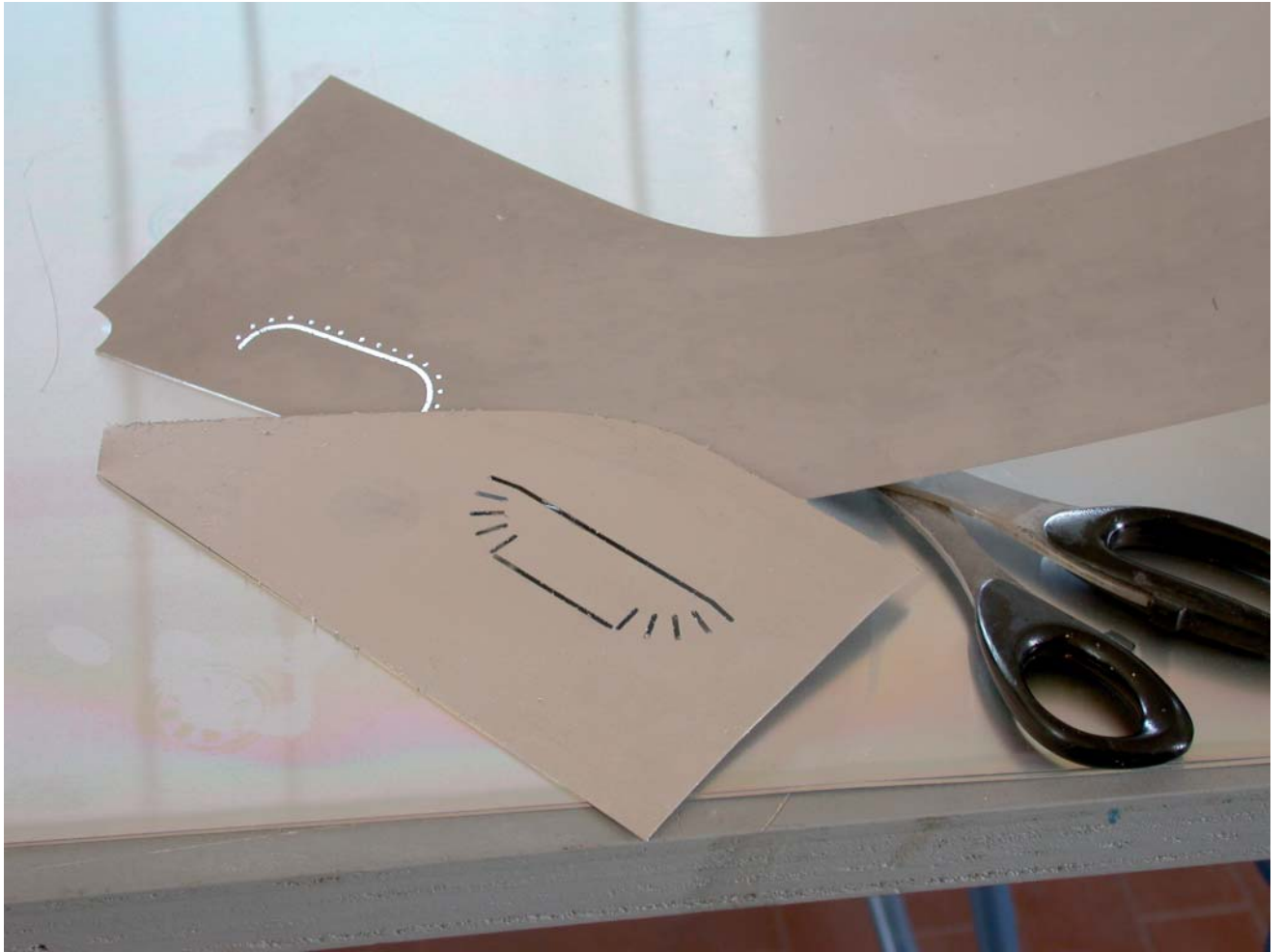



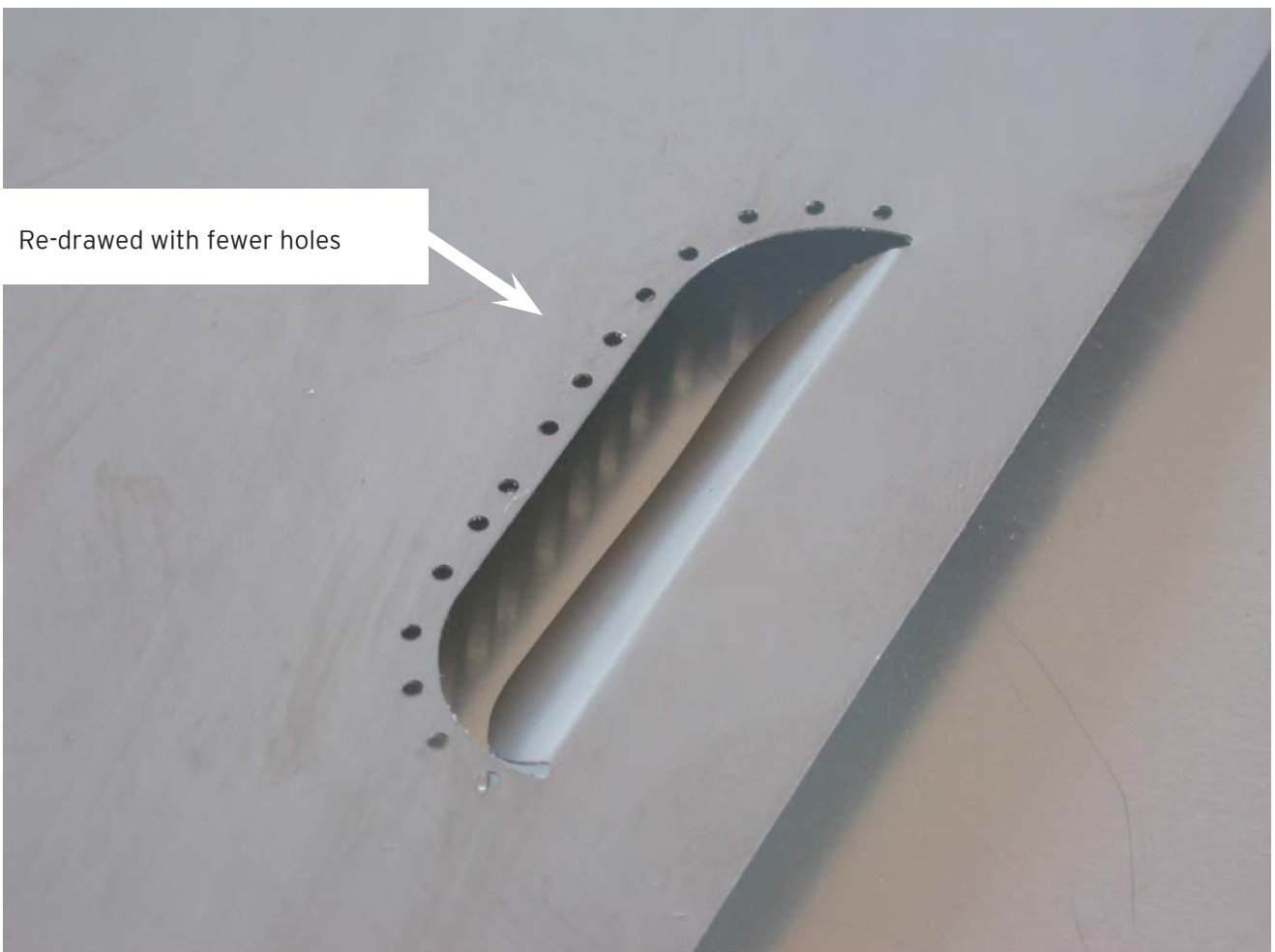







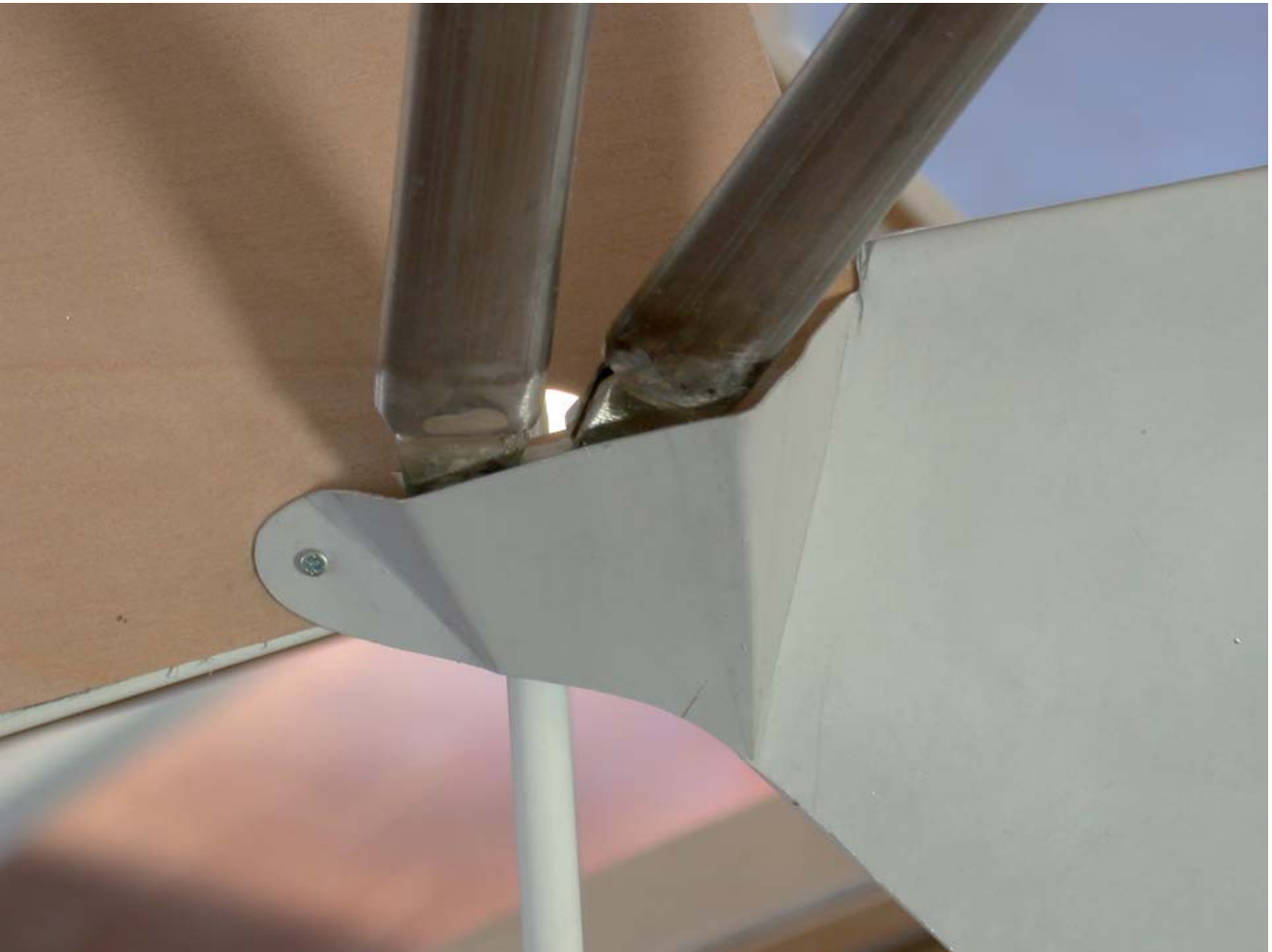

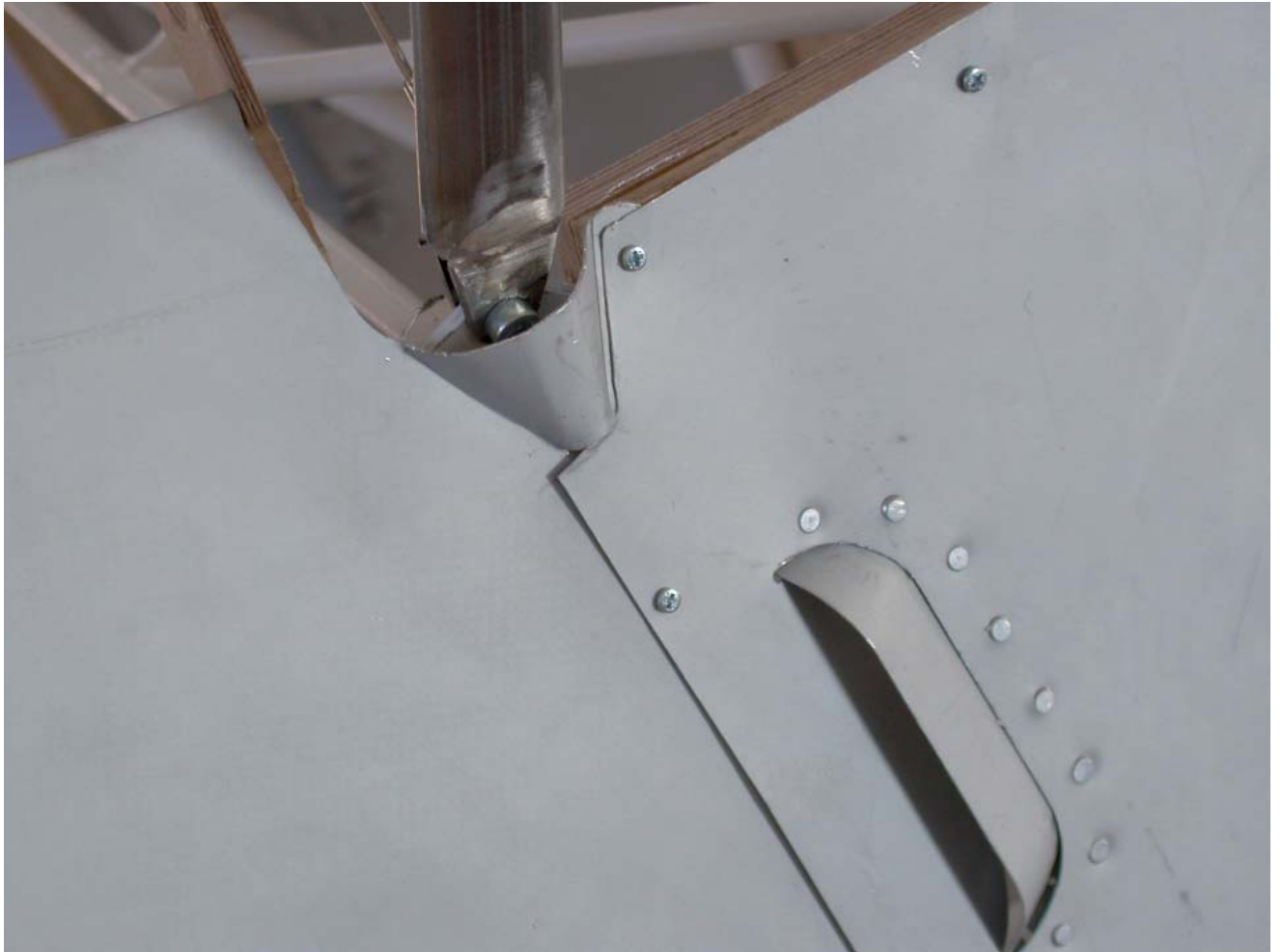



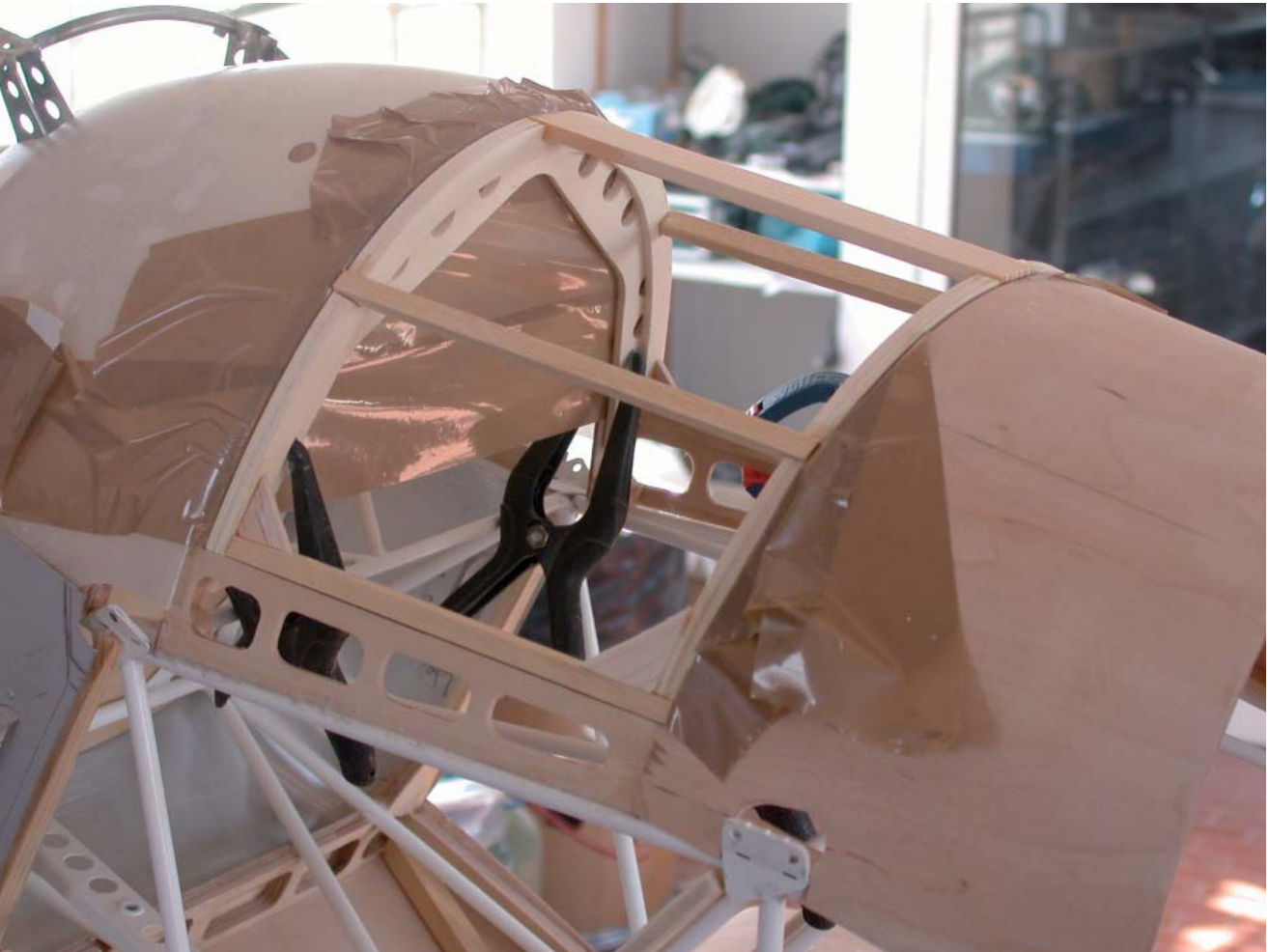

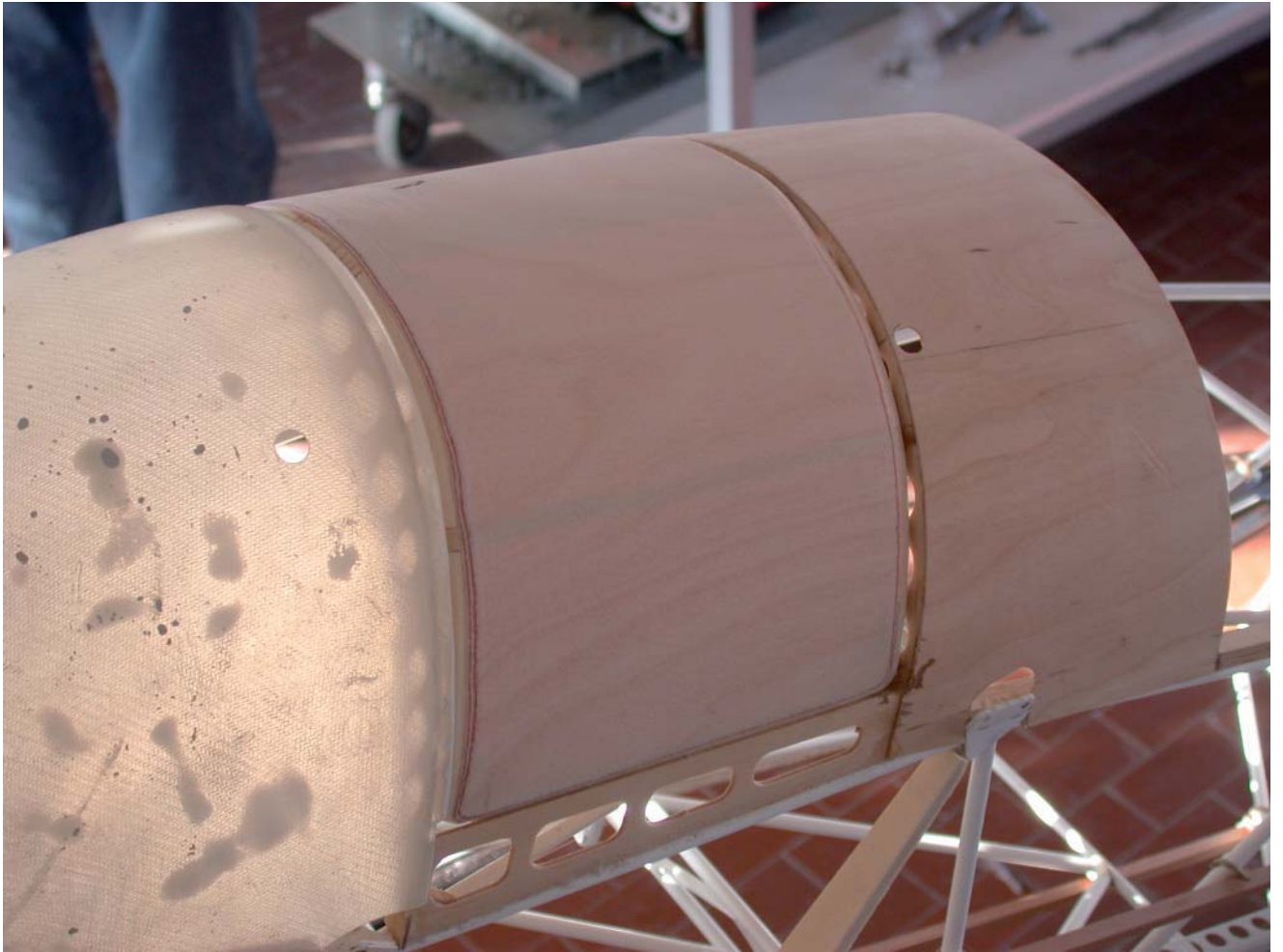



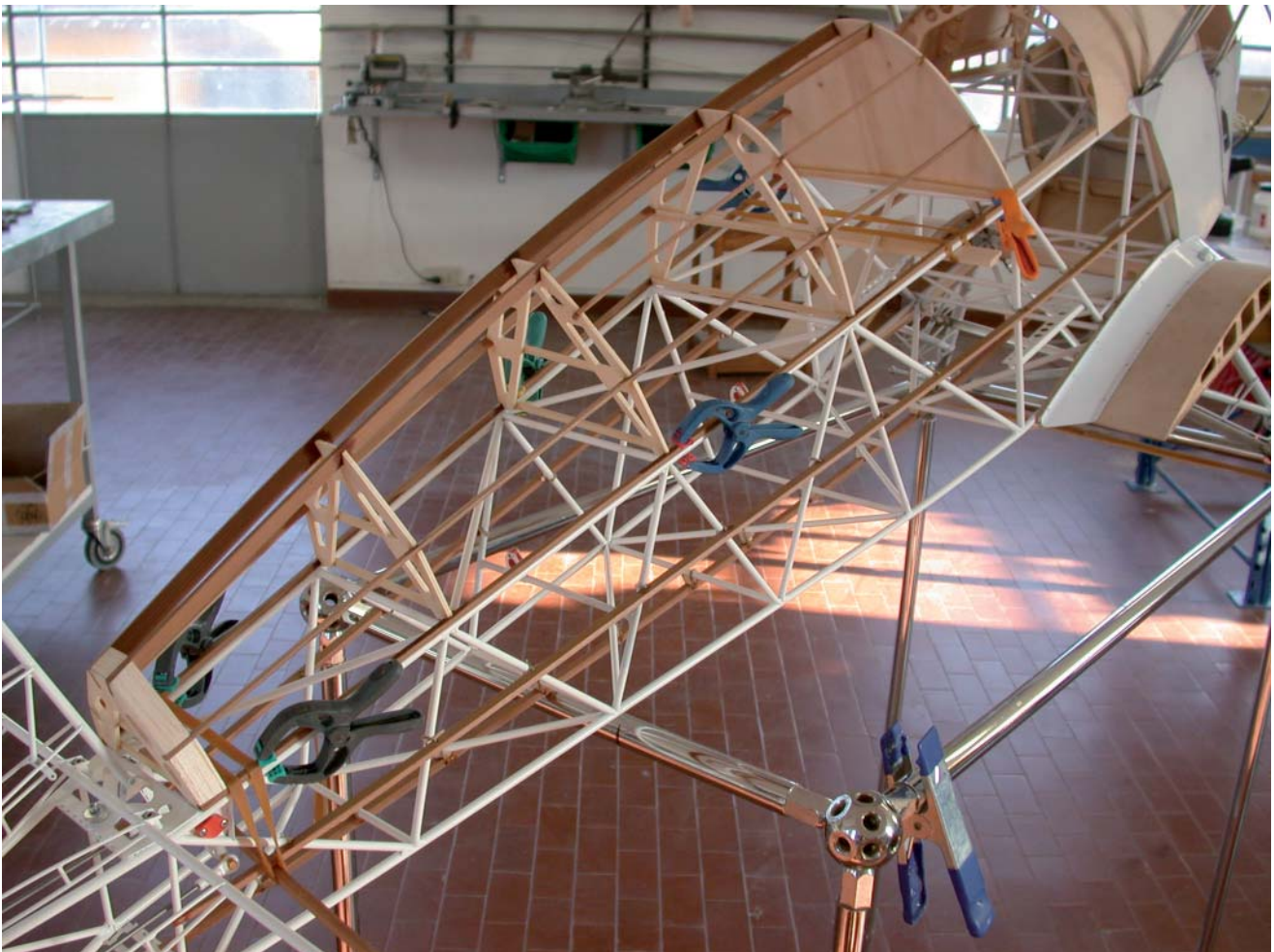
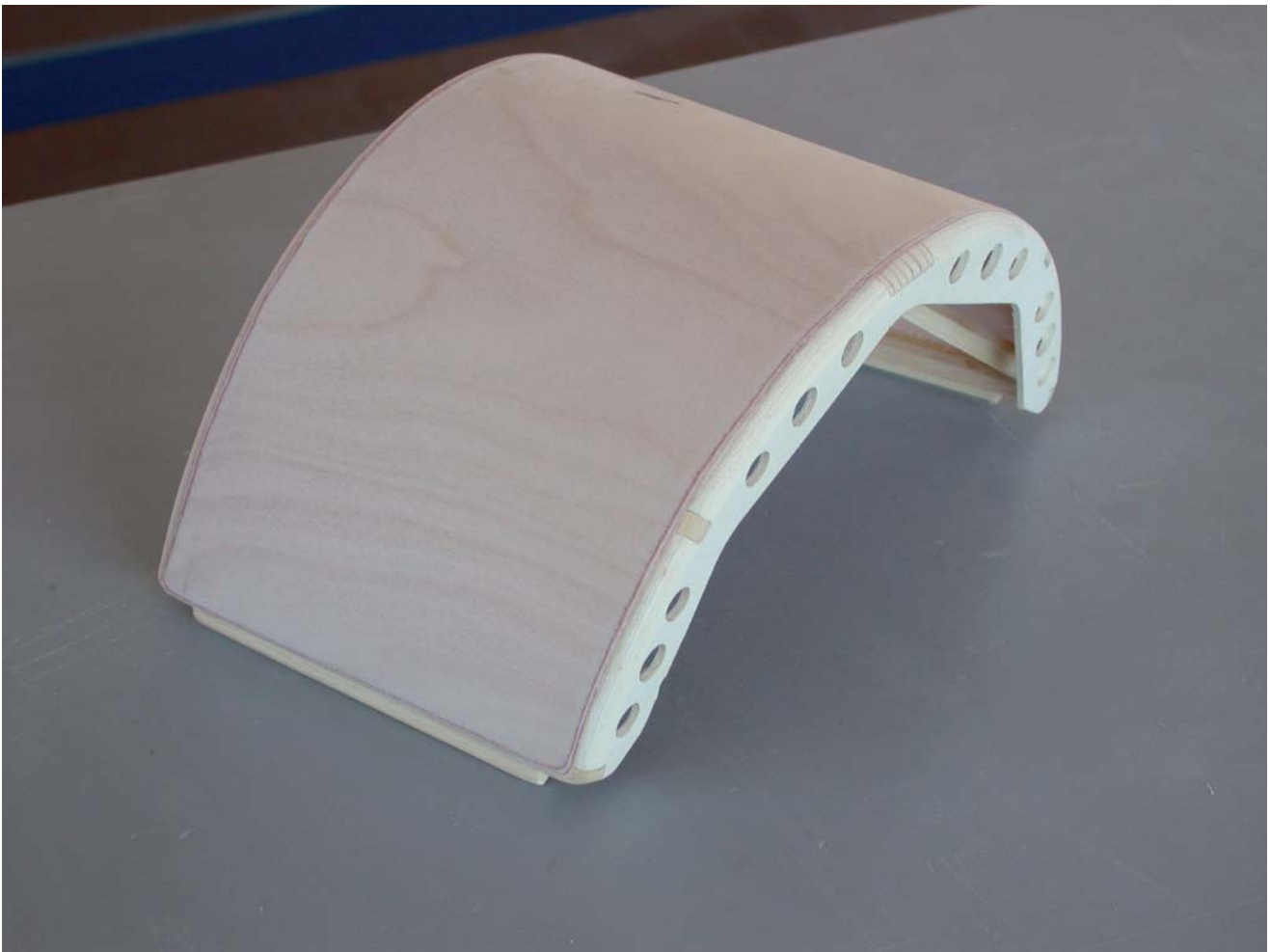















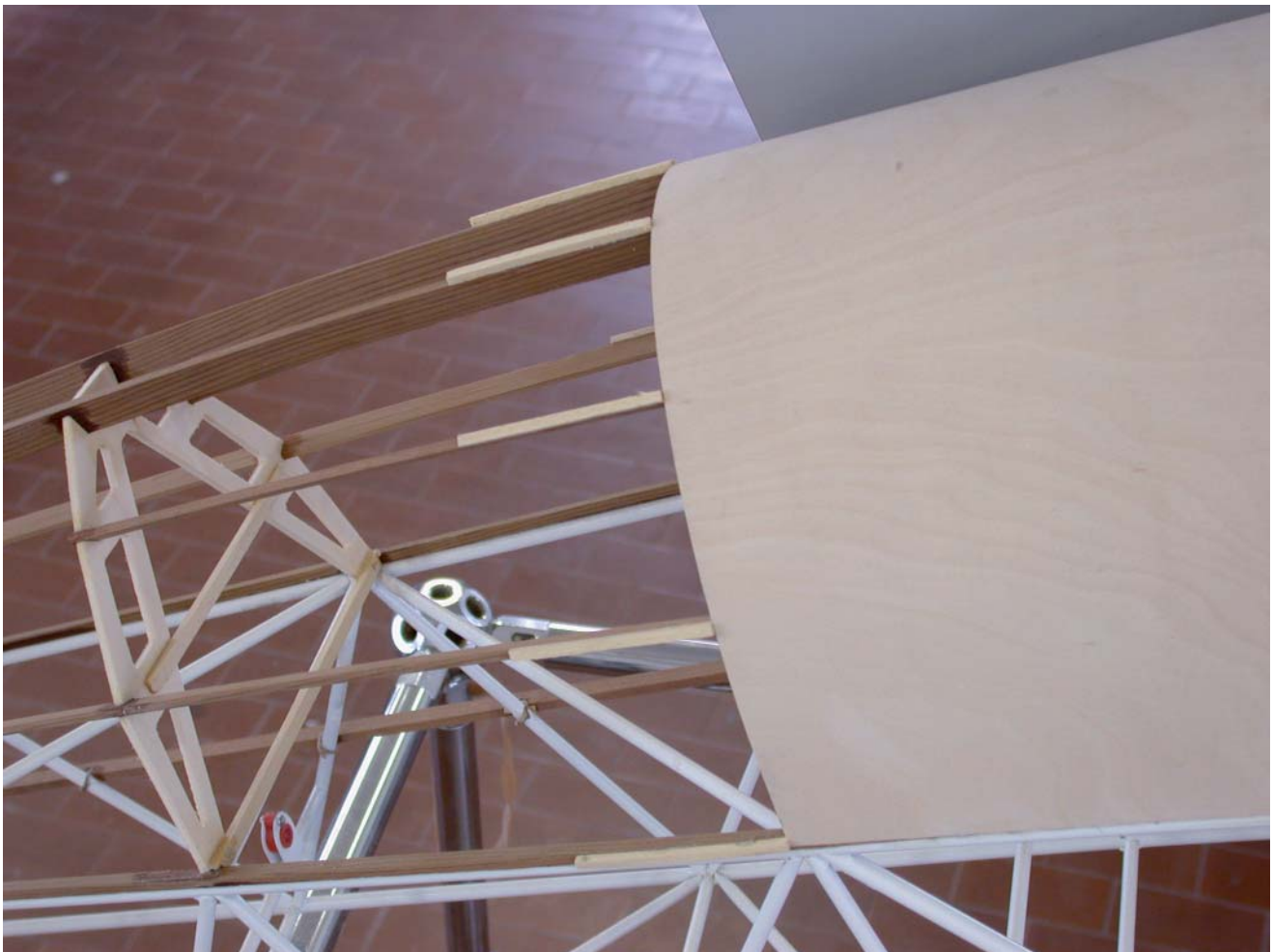





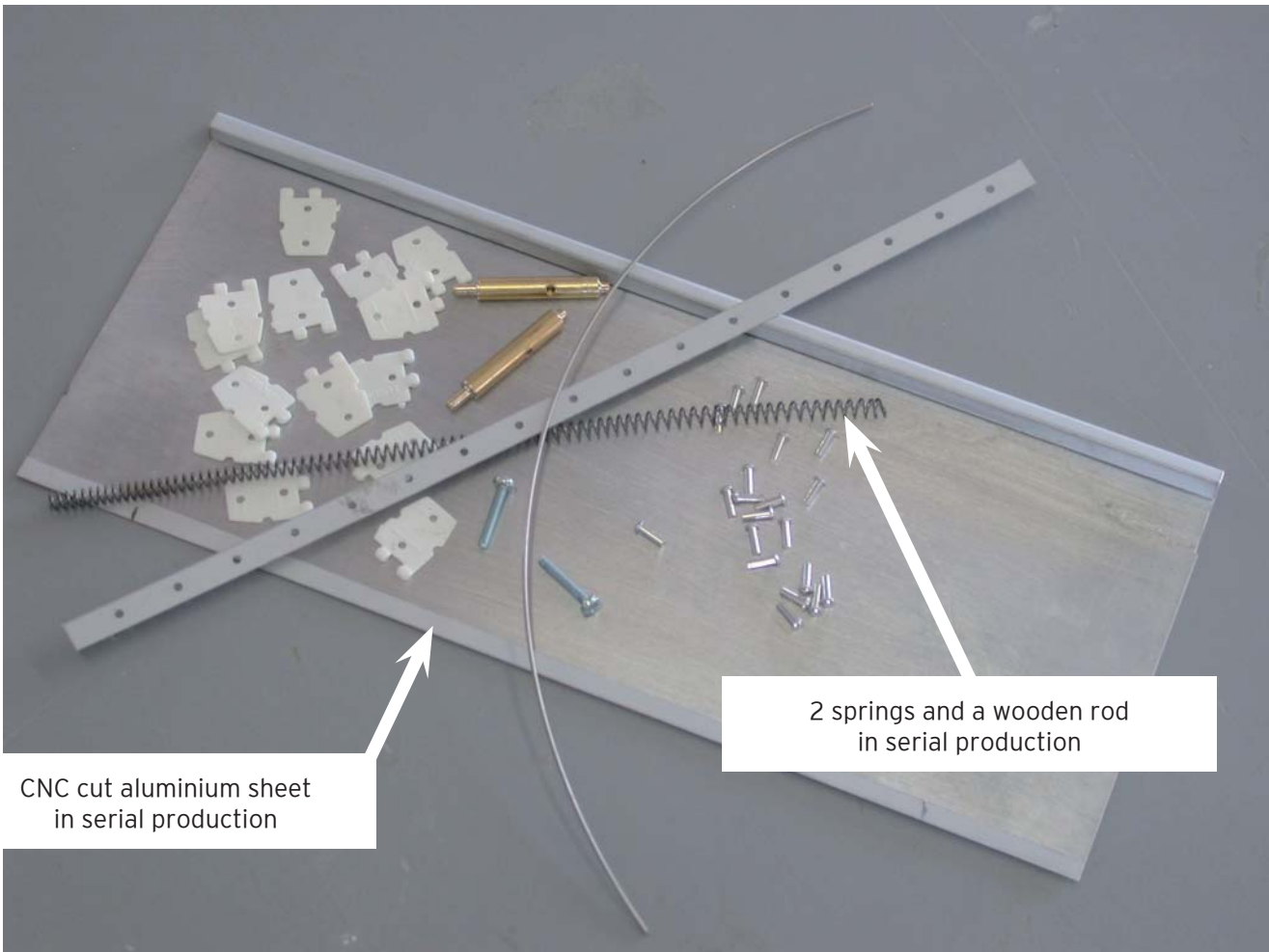

CNC cut aluminium sheet  
in serial production

2 springs and a wooden rod  
in serial production



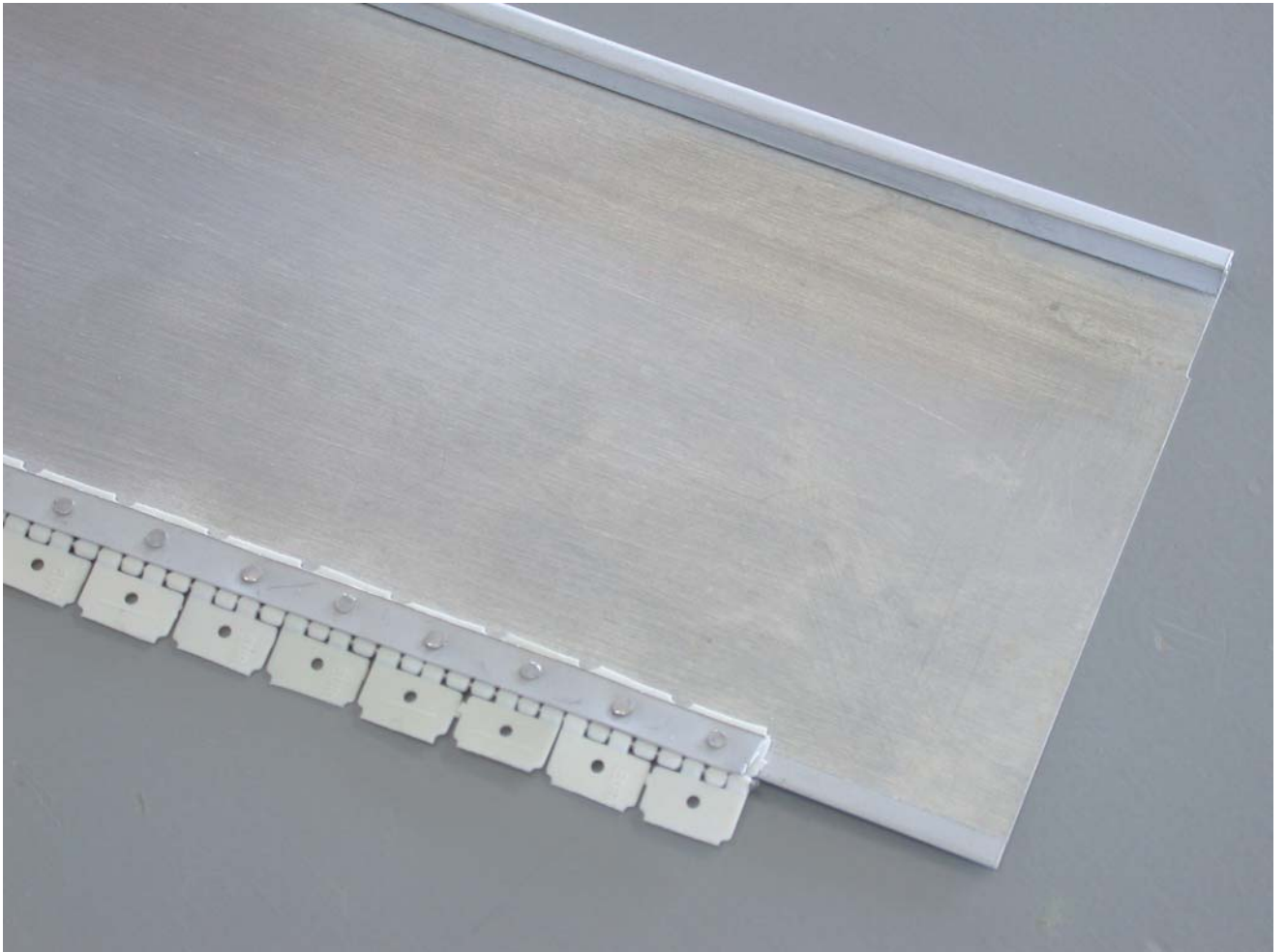
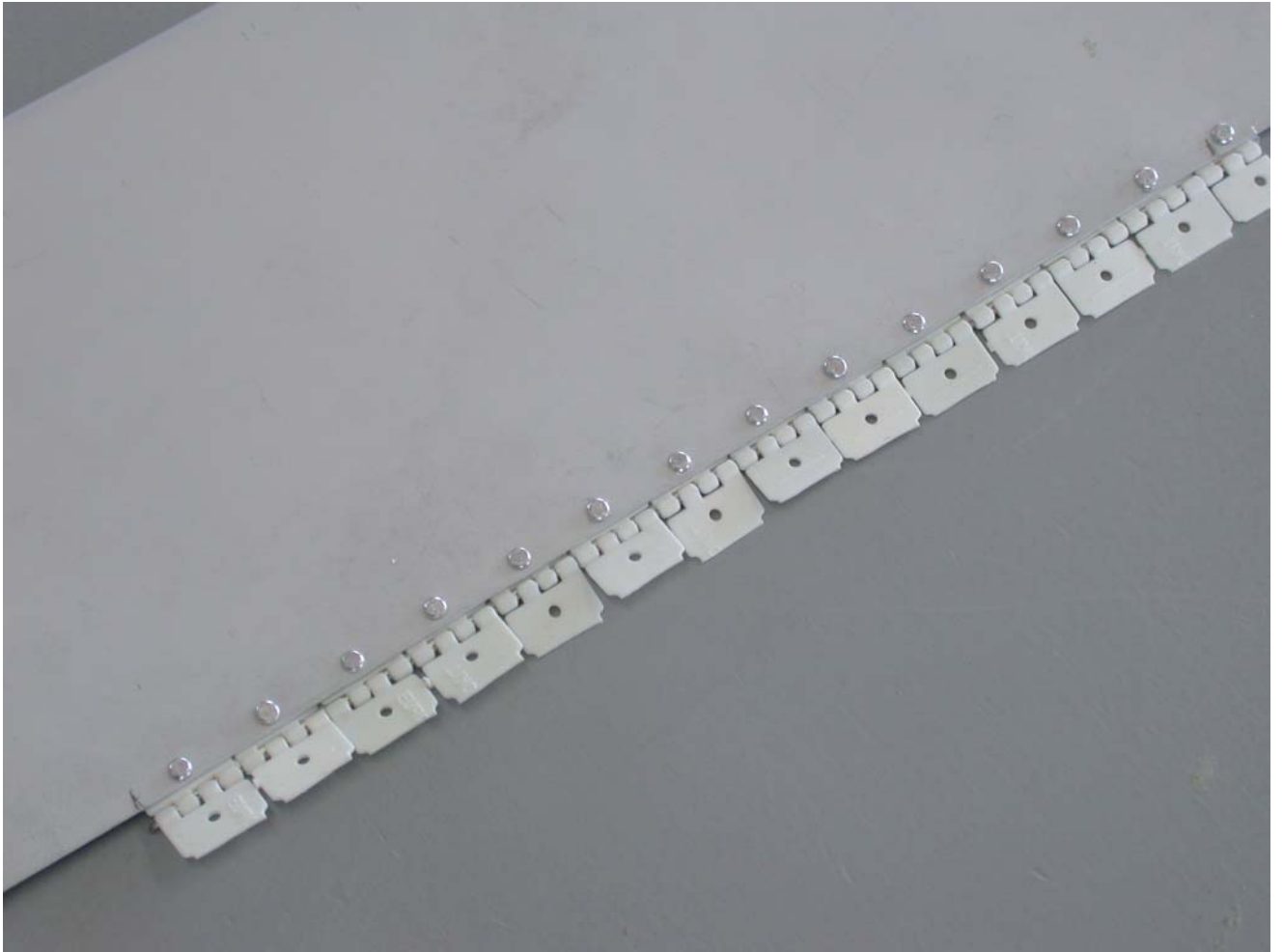



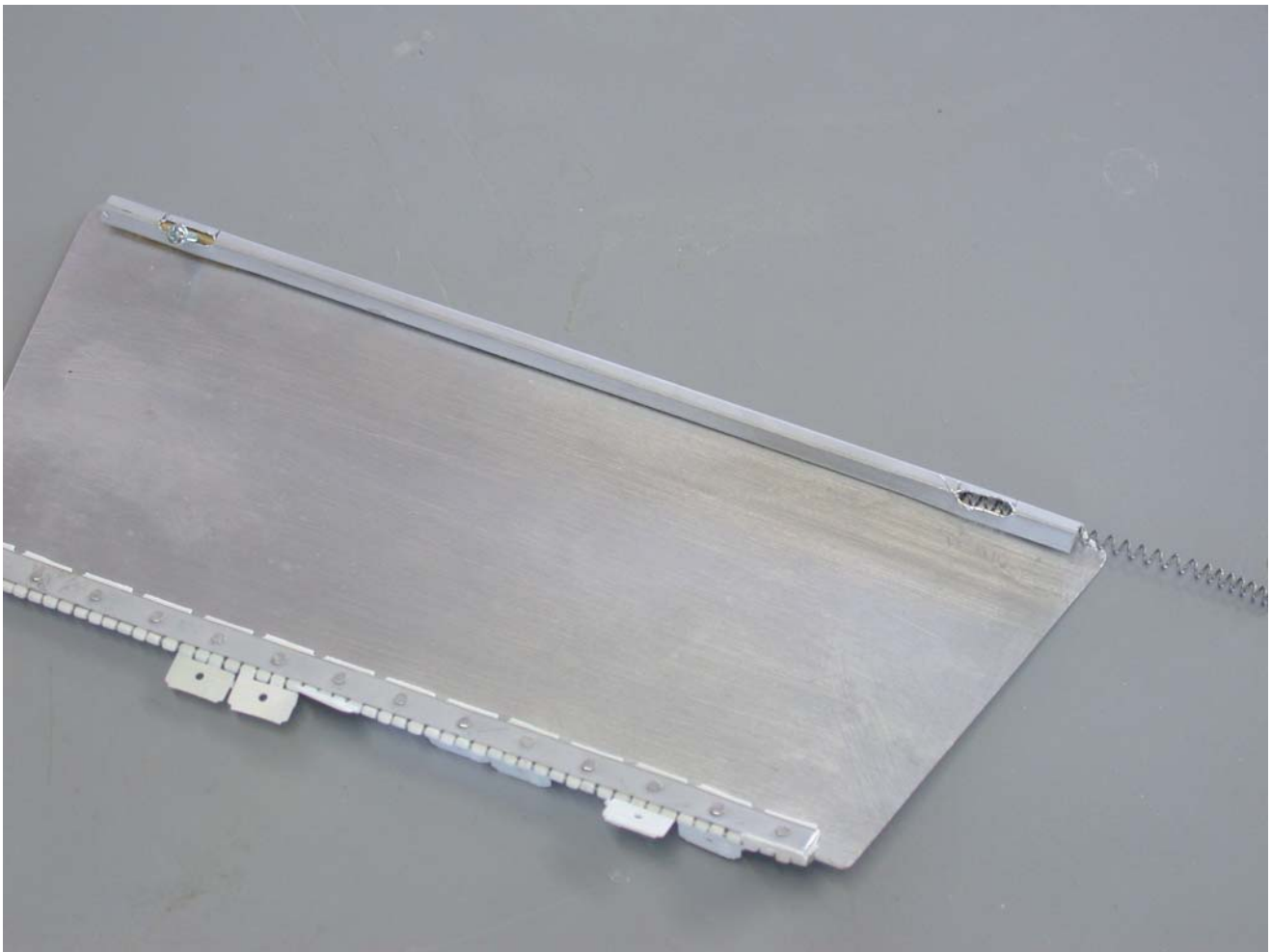







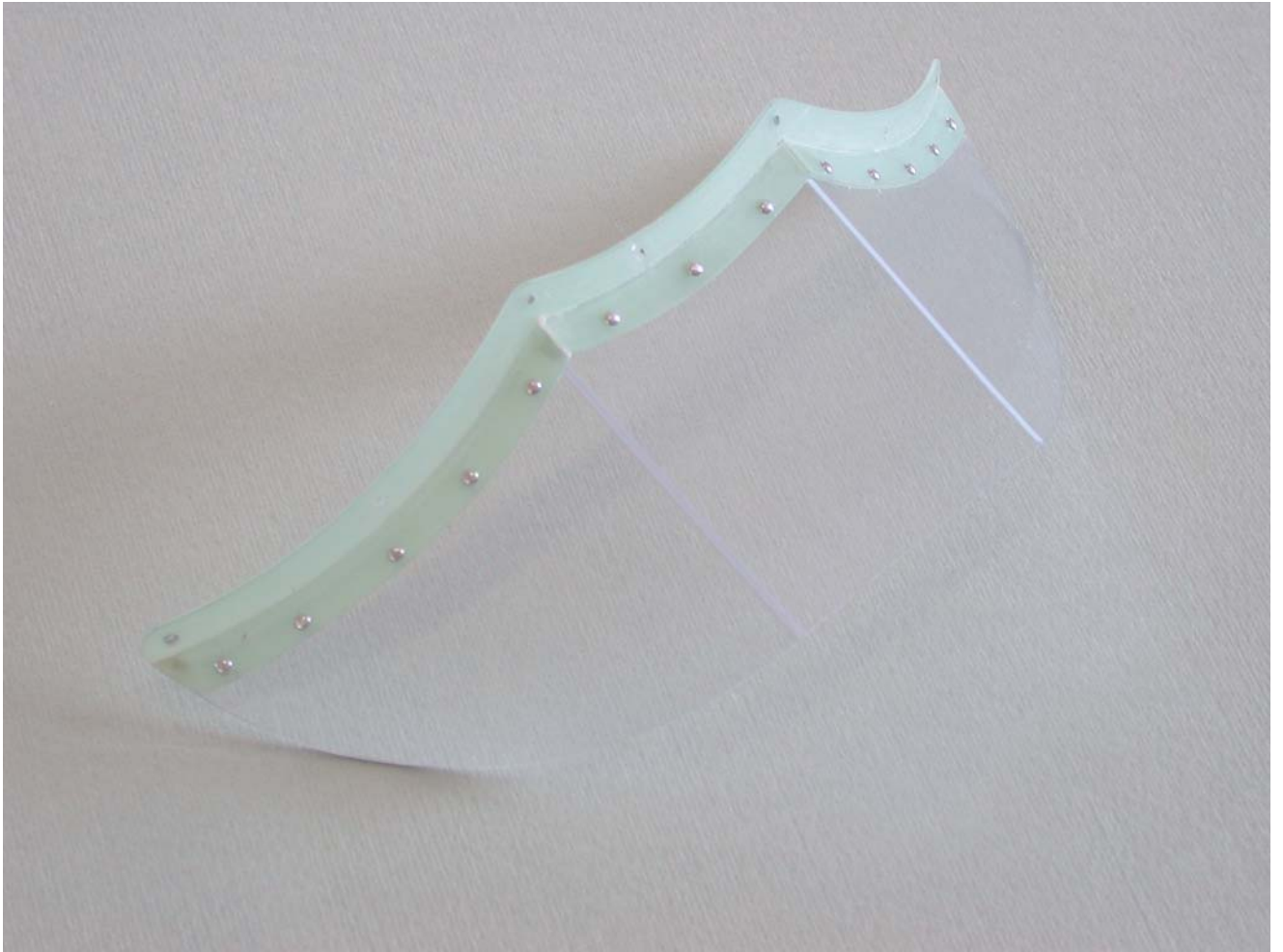



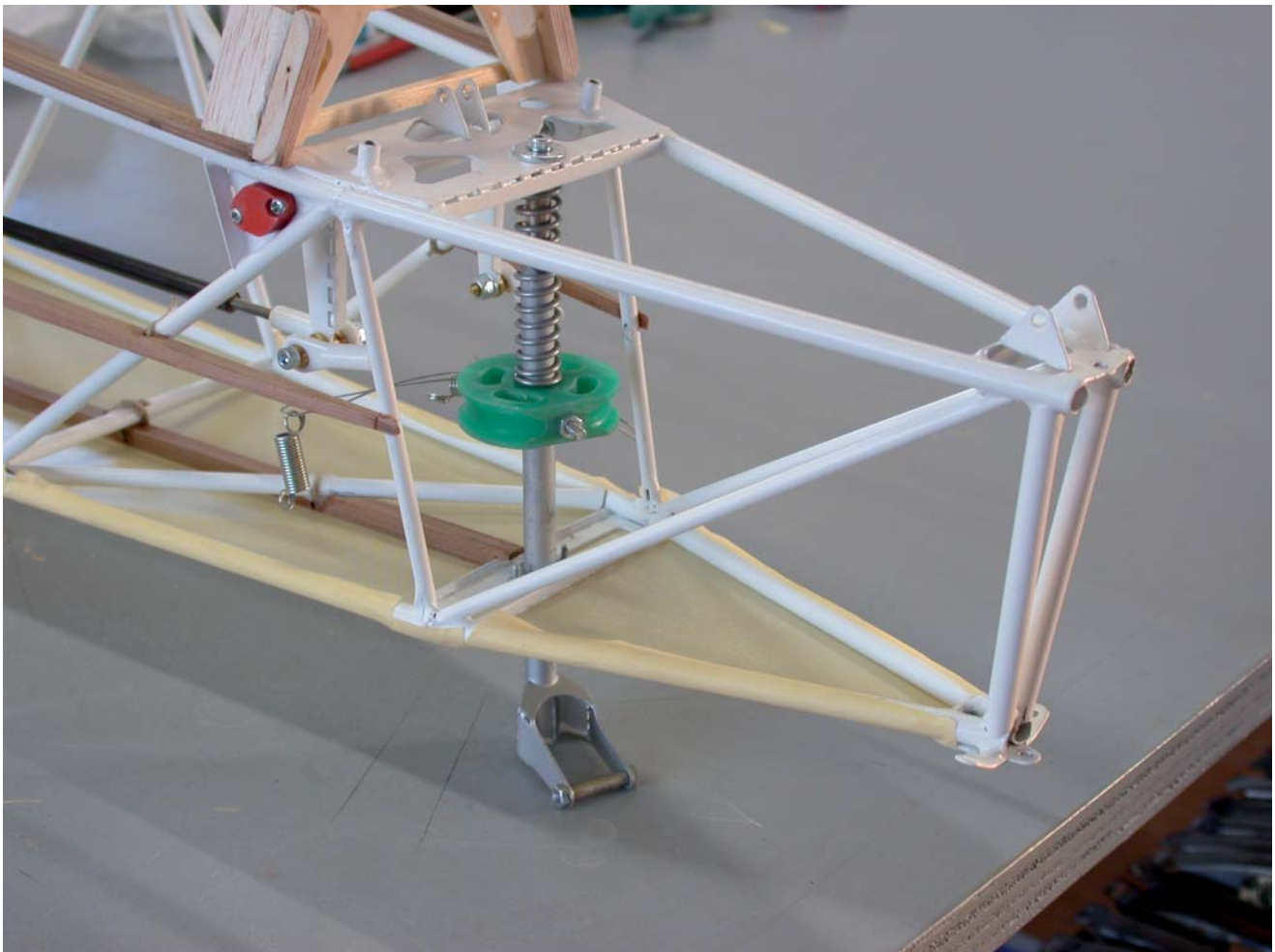
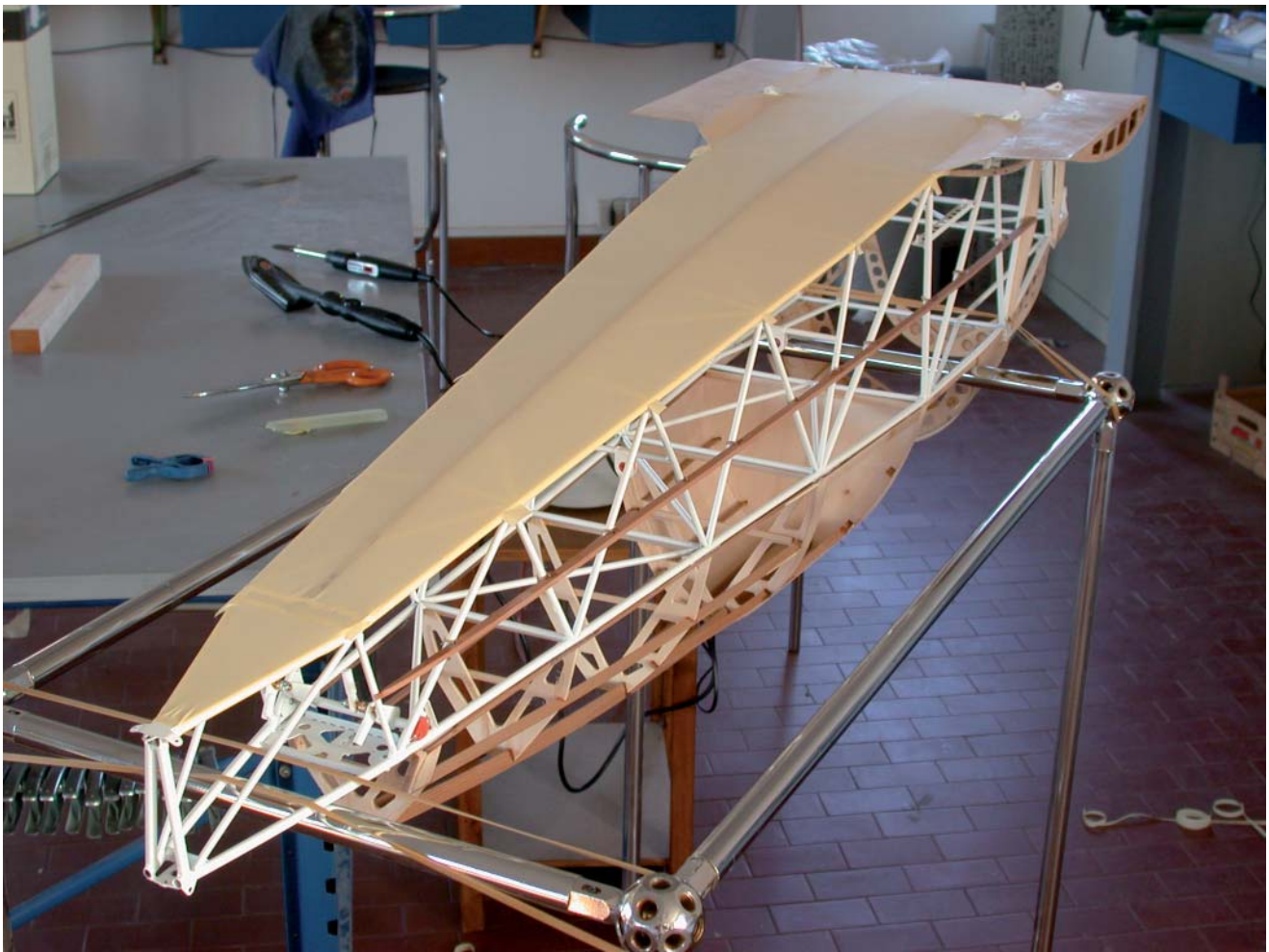

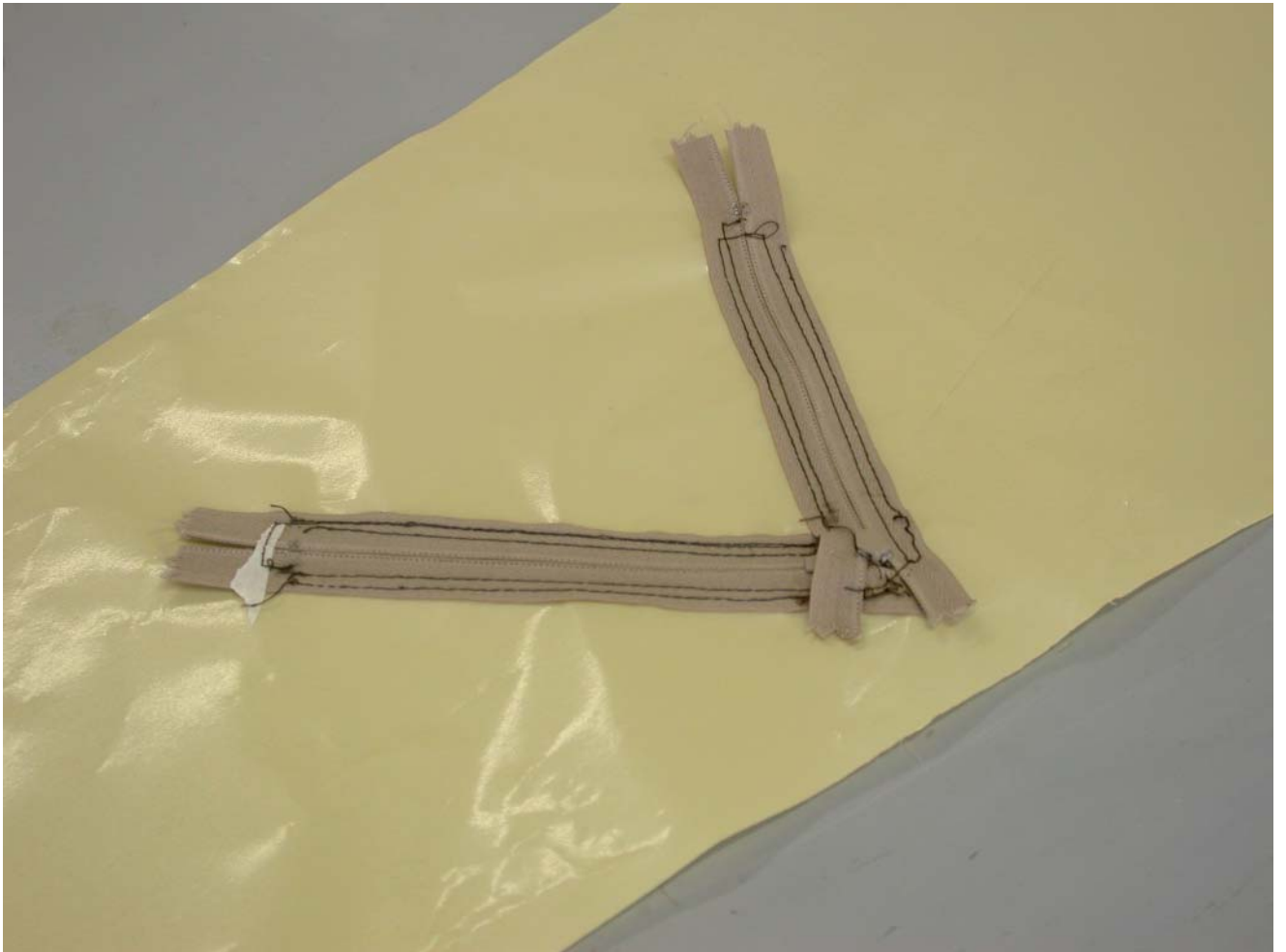
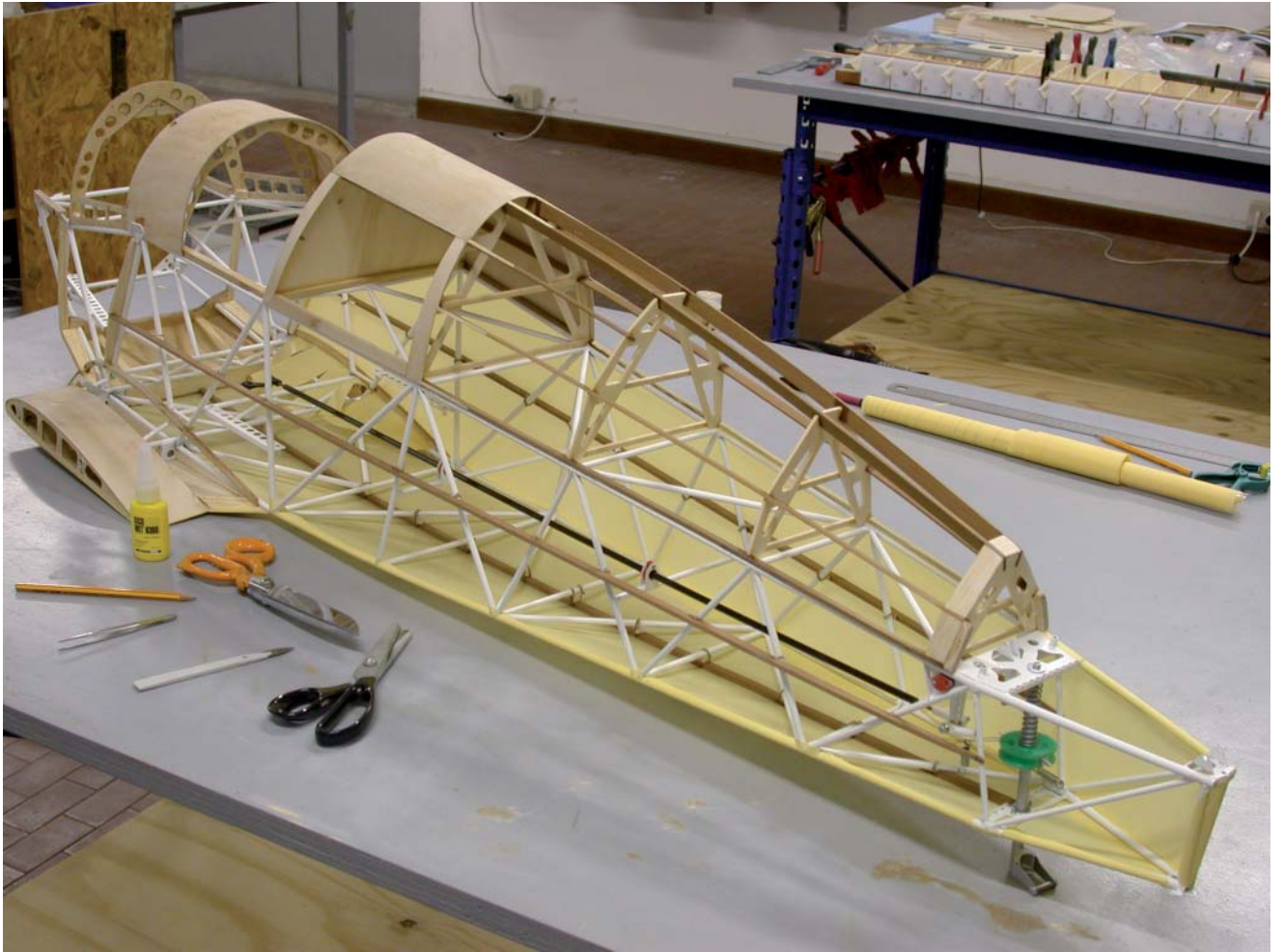



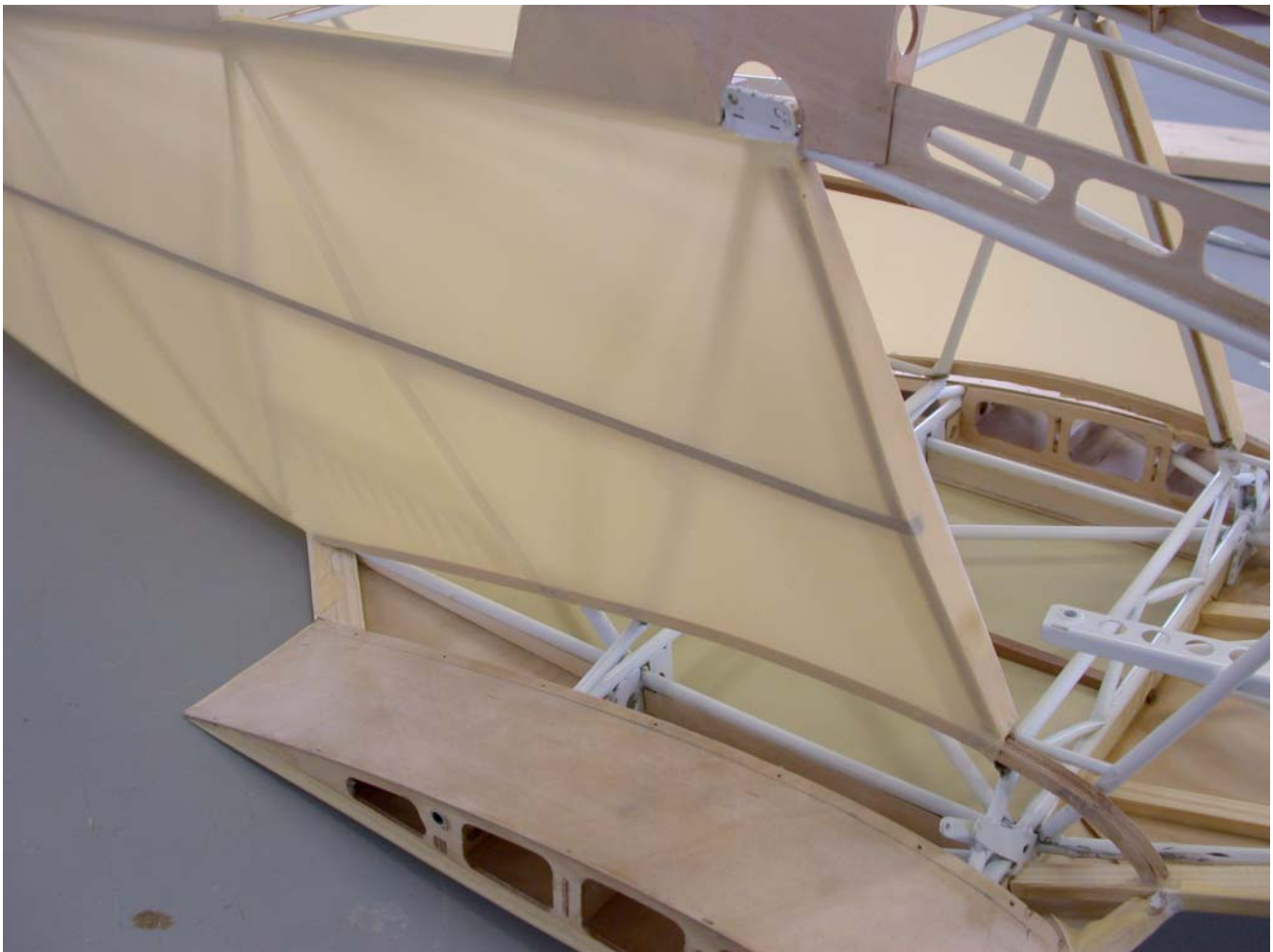
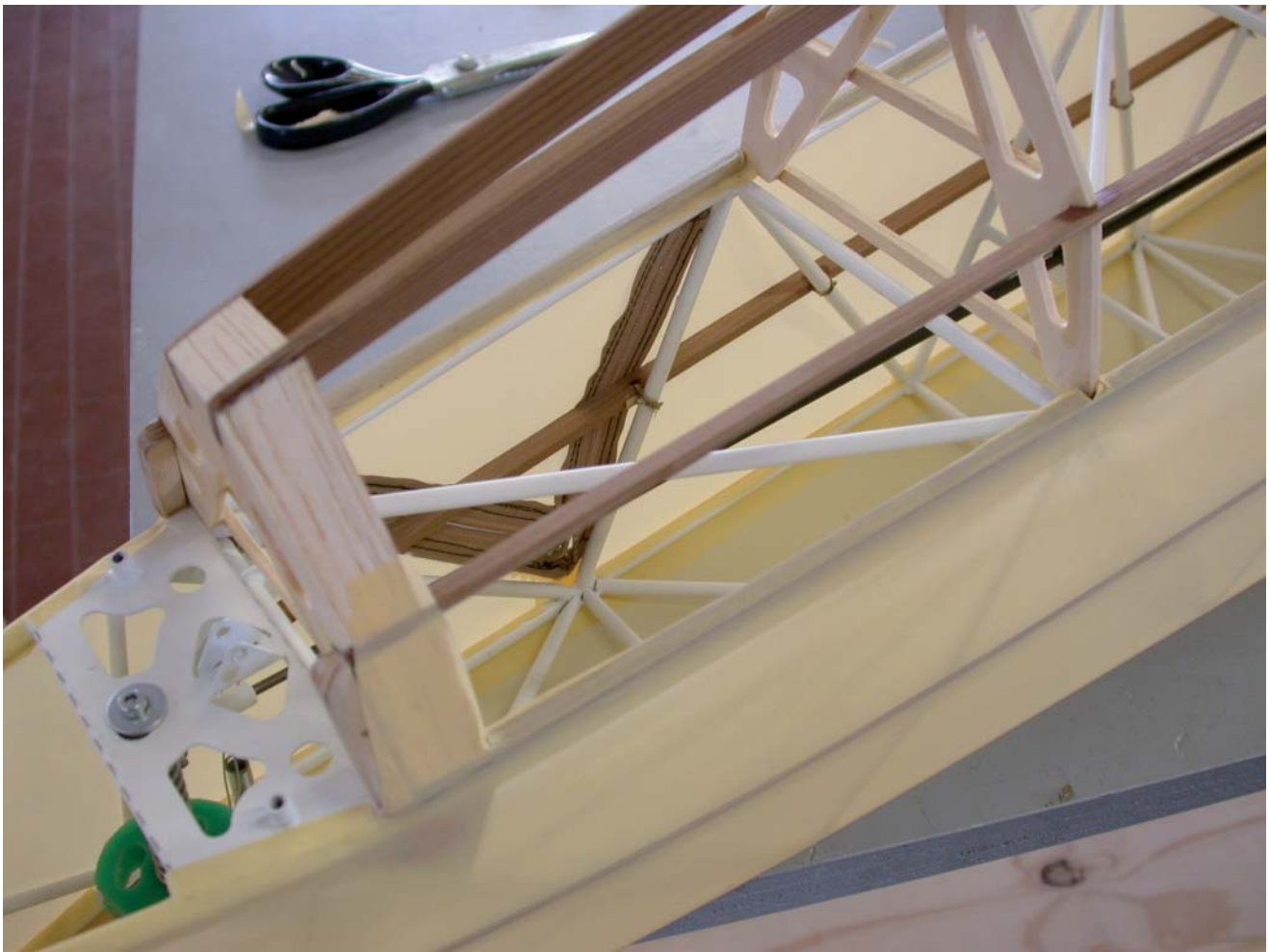

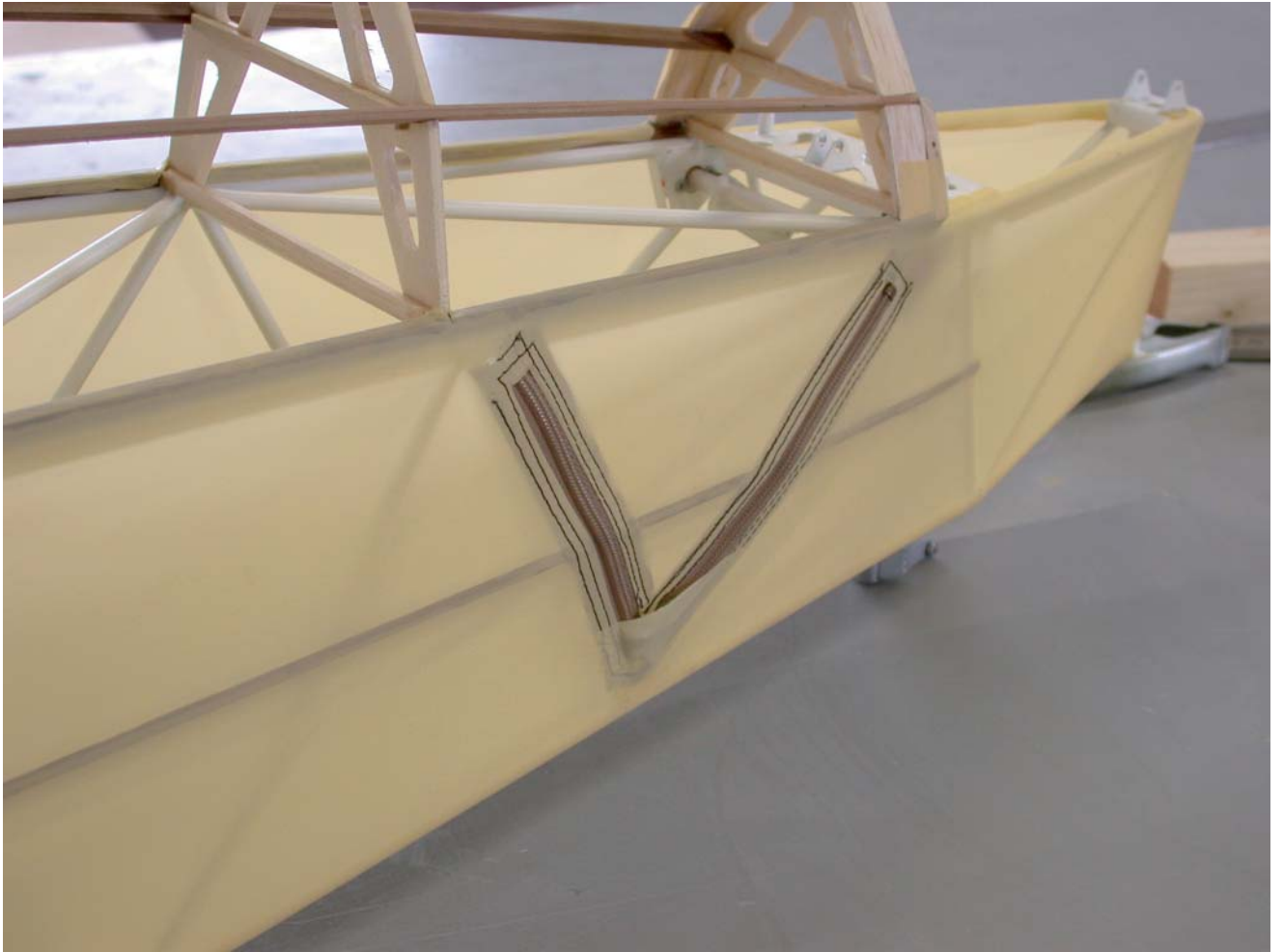



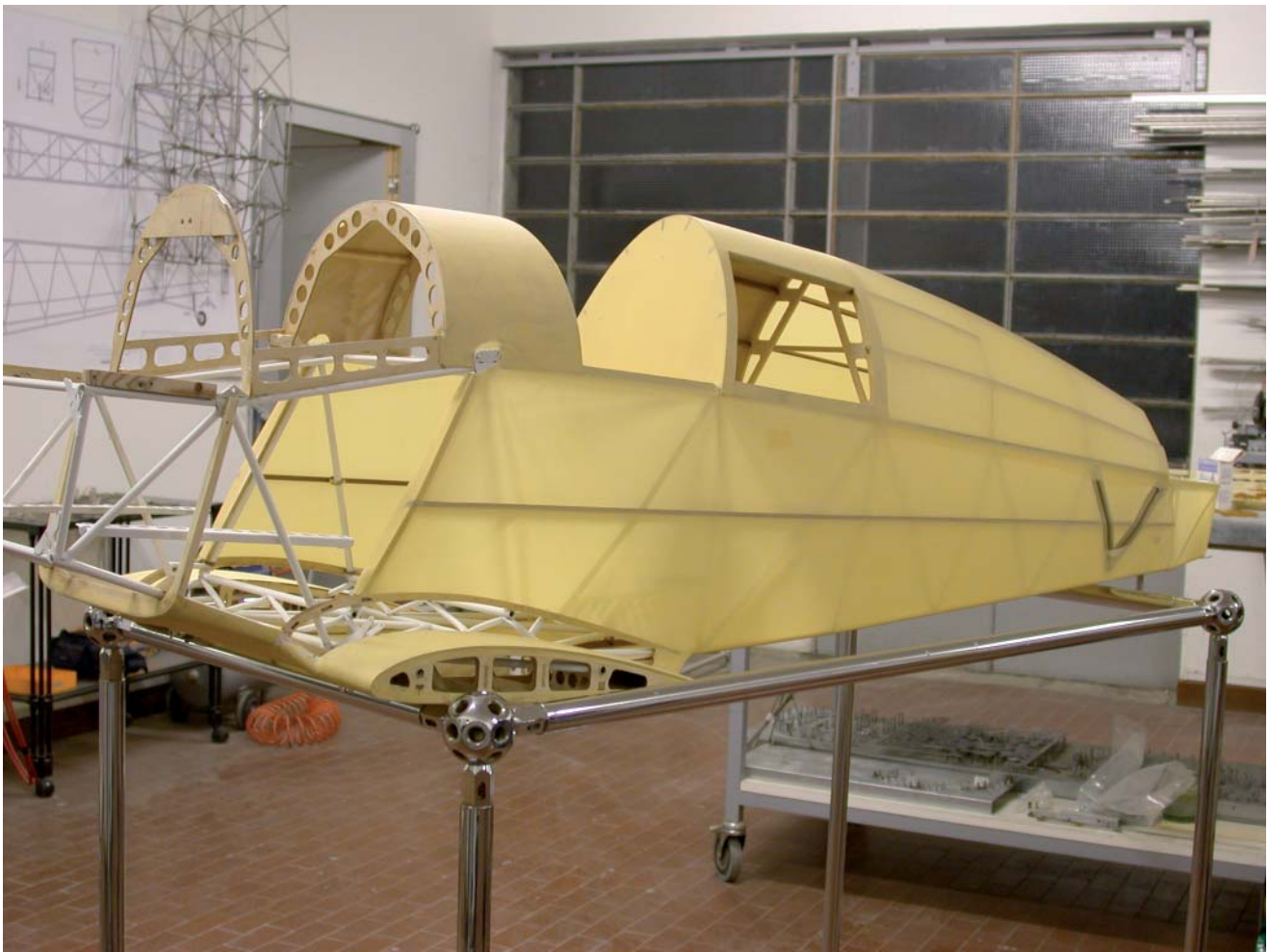





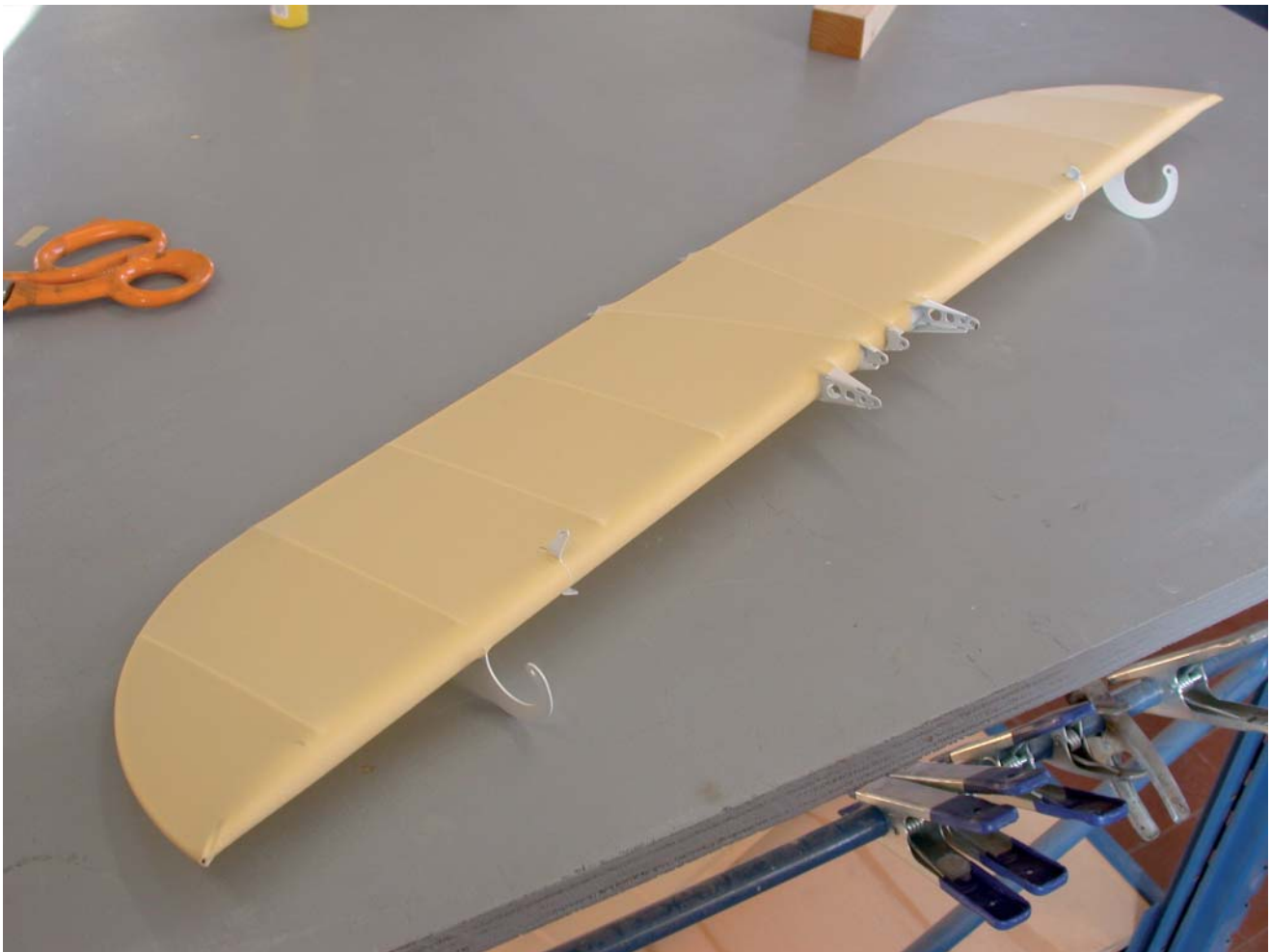



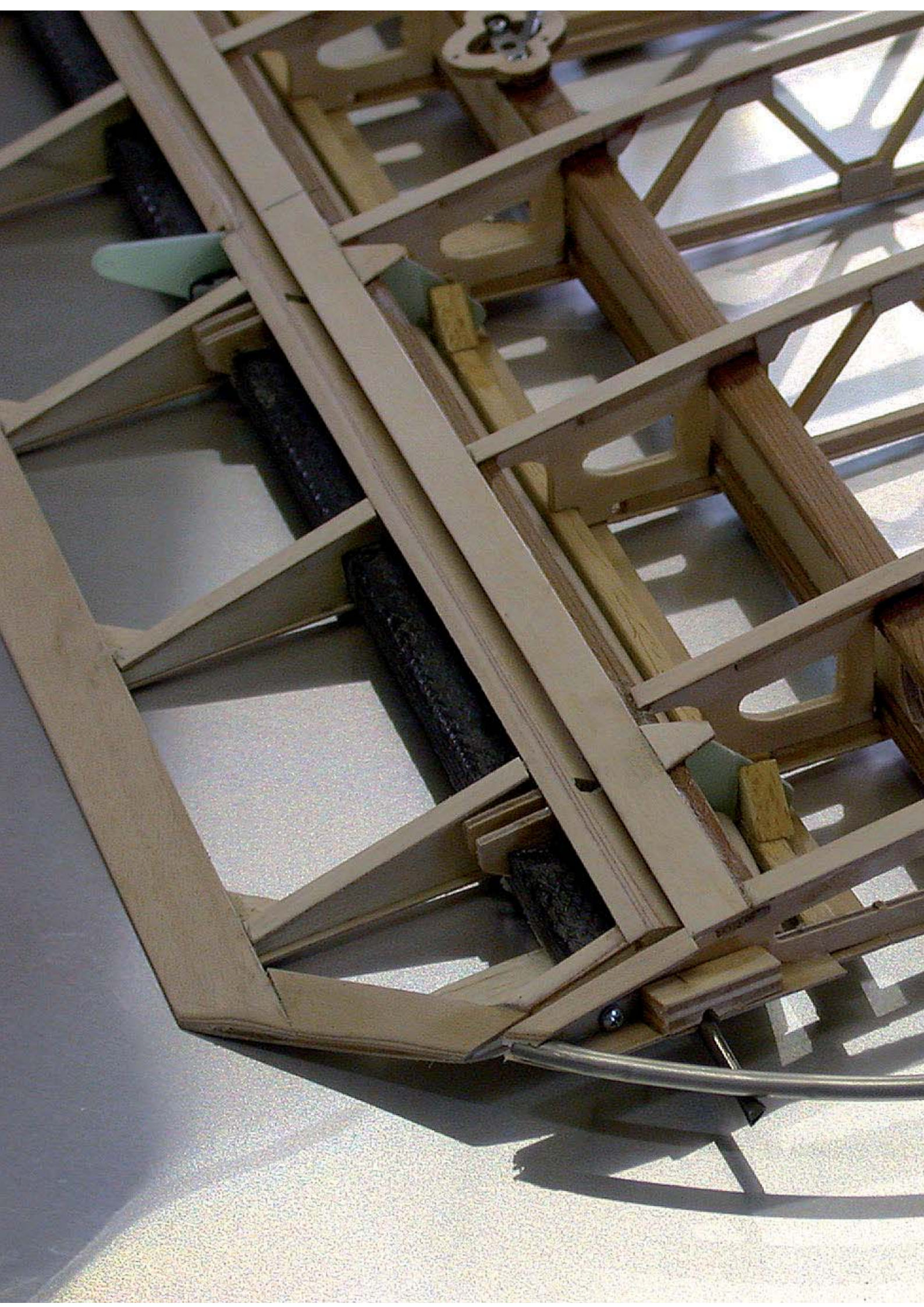





## 2. WINGS

### NOTE:

The pictures are of the prototype.  
In the serial production we can have made  
some improvements.

The CNC ribs wing construction is similar.



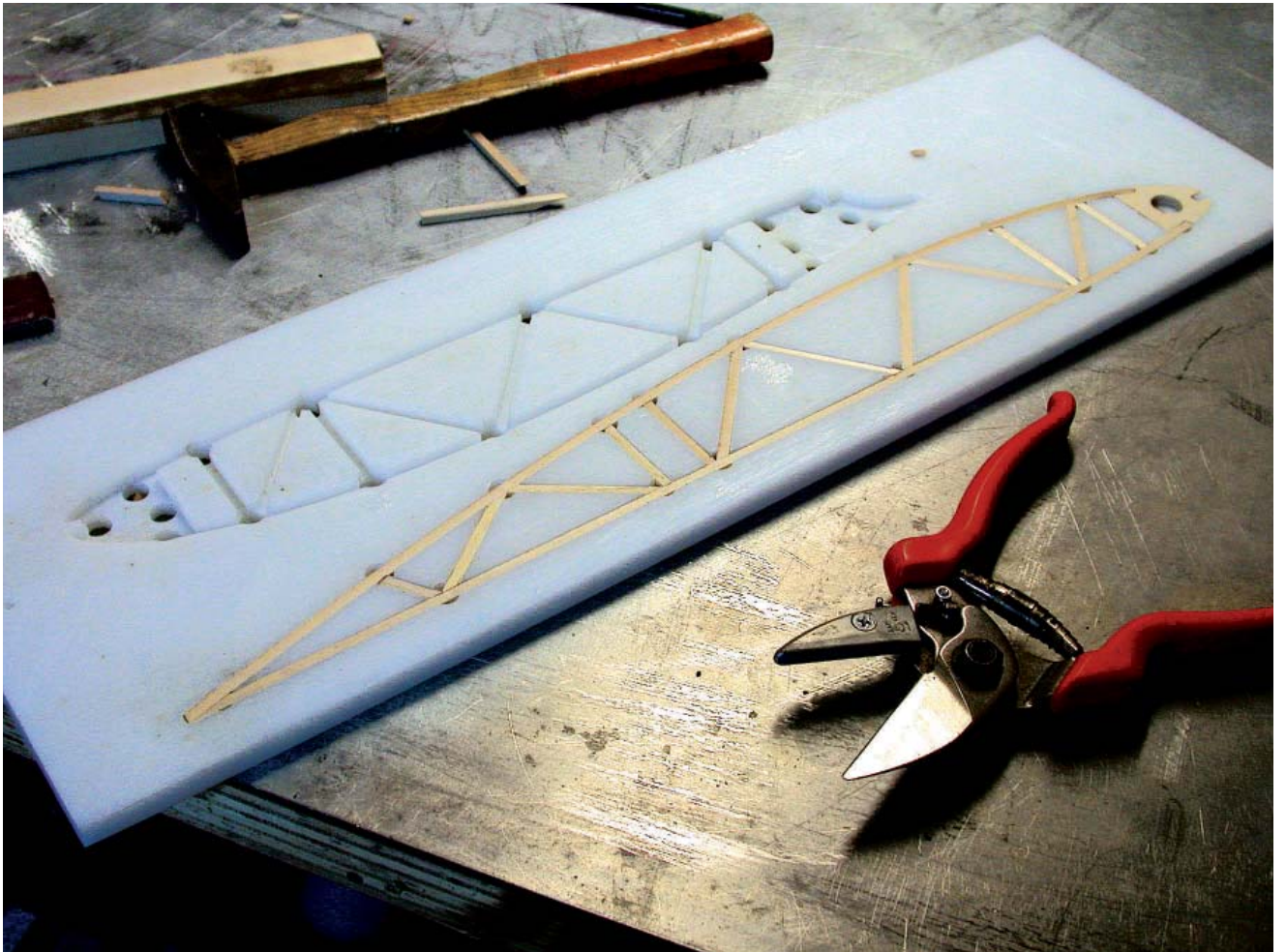
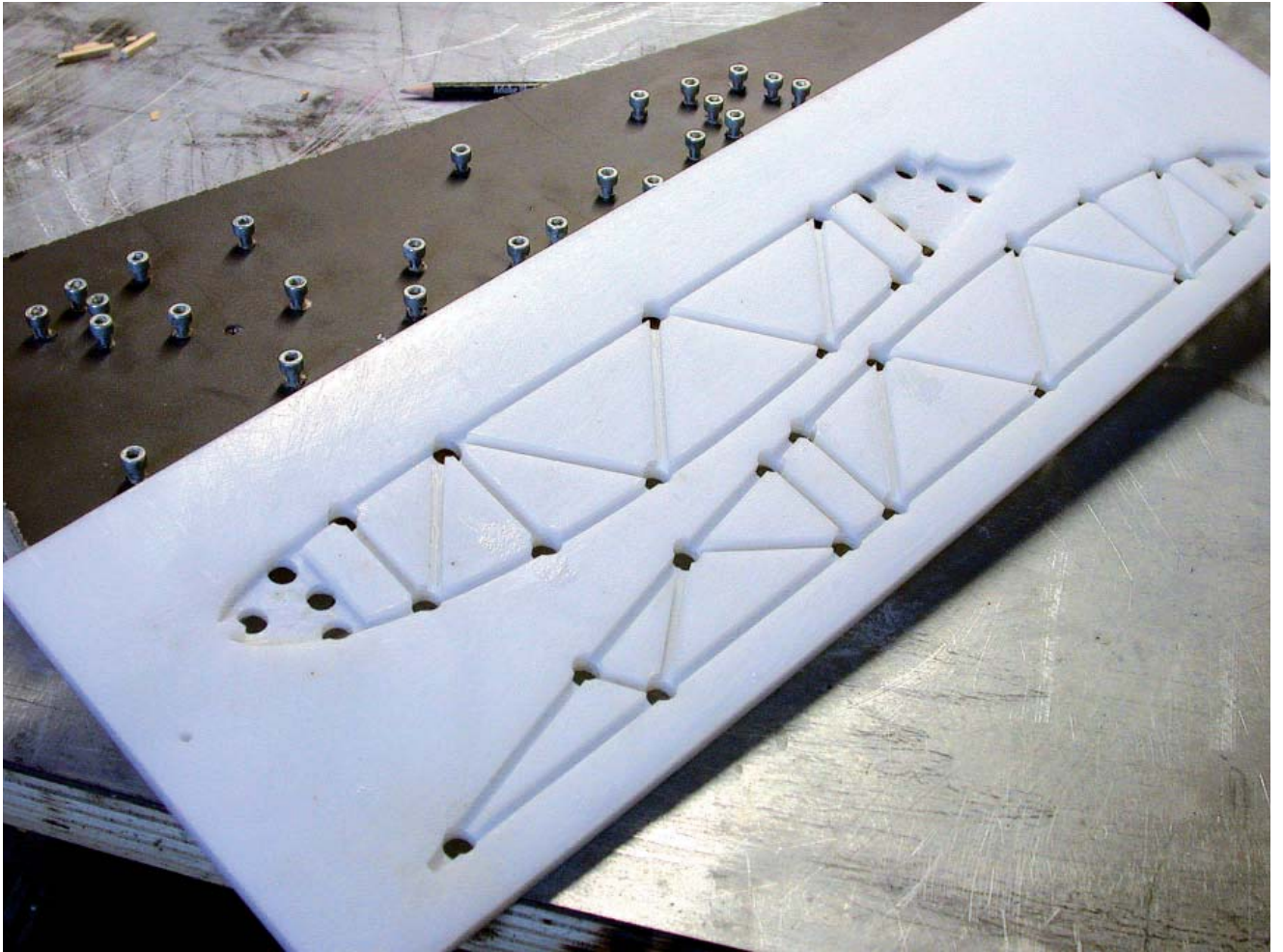



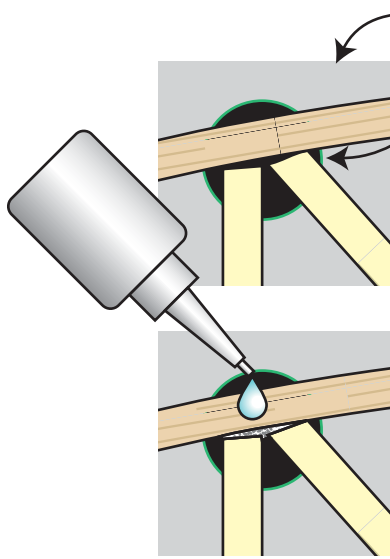

NYLON MOLD

LOW ACCURACY IS BETTER!

PUT A BIT OF BICARBONATE POWDER  
IN THE SPACE BETWEEN THE STRIPS  
AND GLUE WITH A DROP OF CYANOACRYLATE.

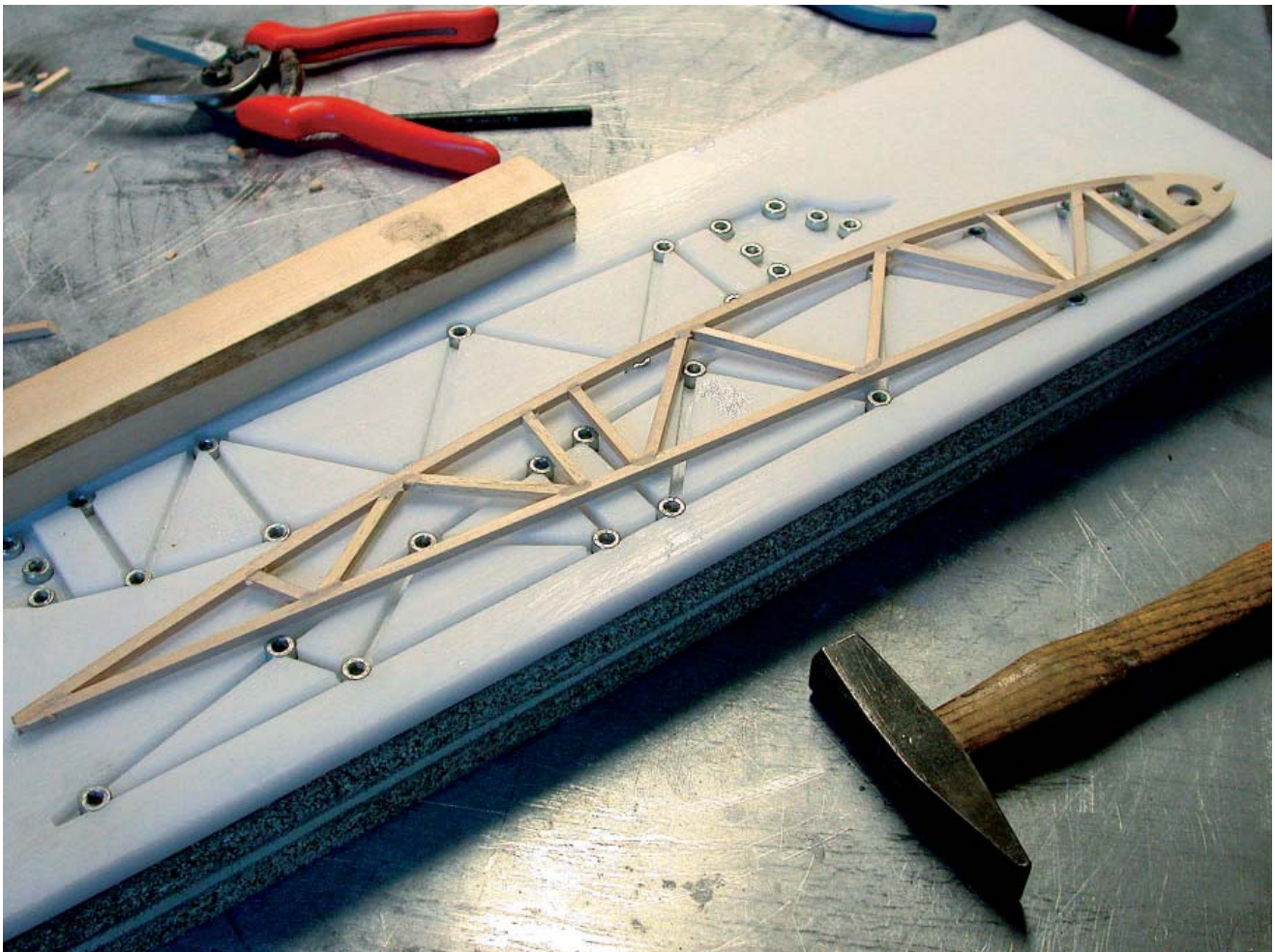



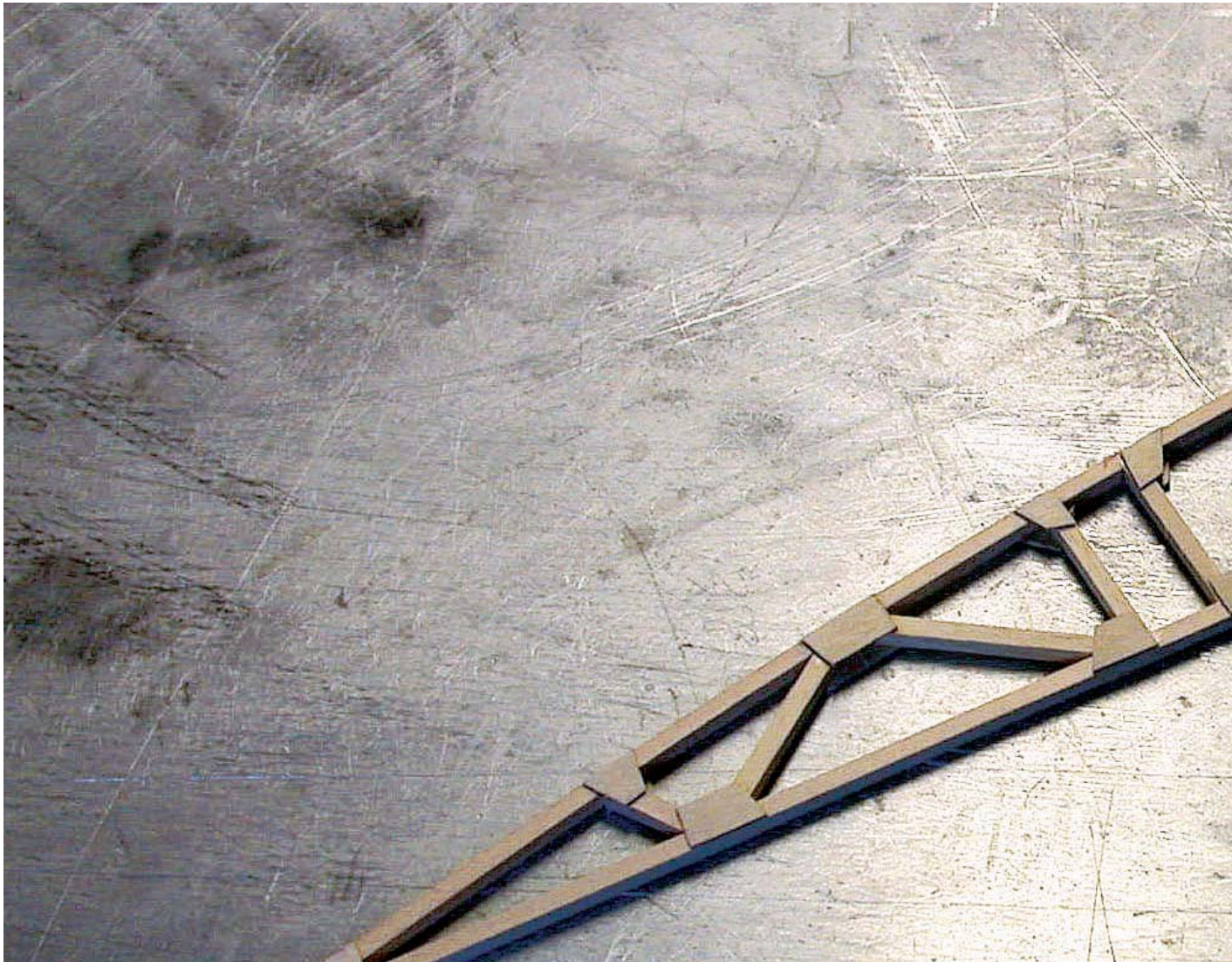
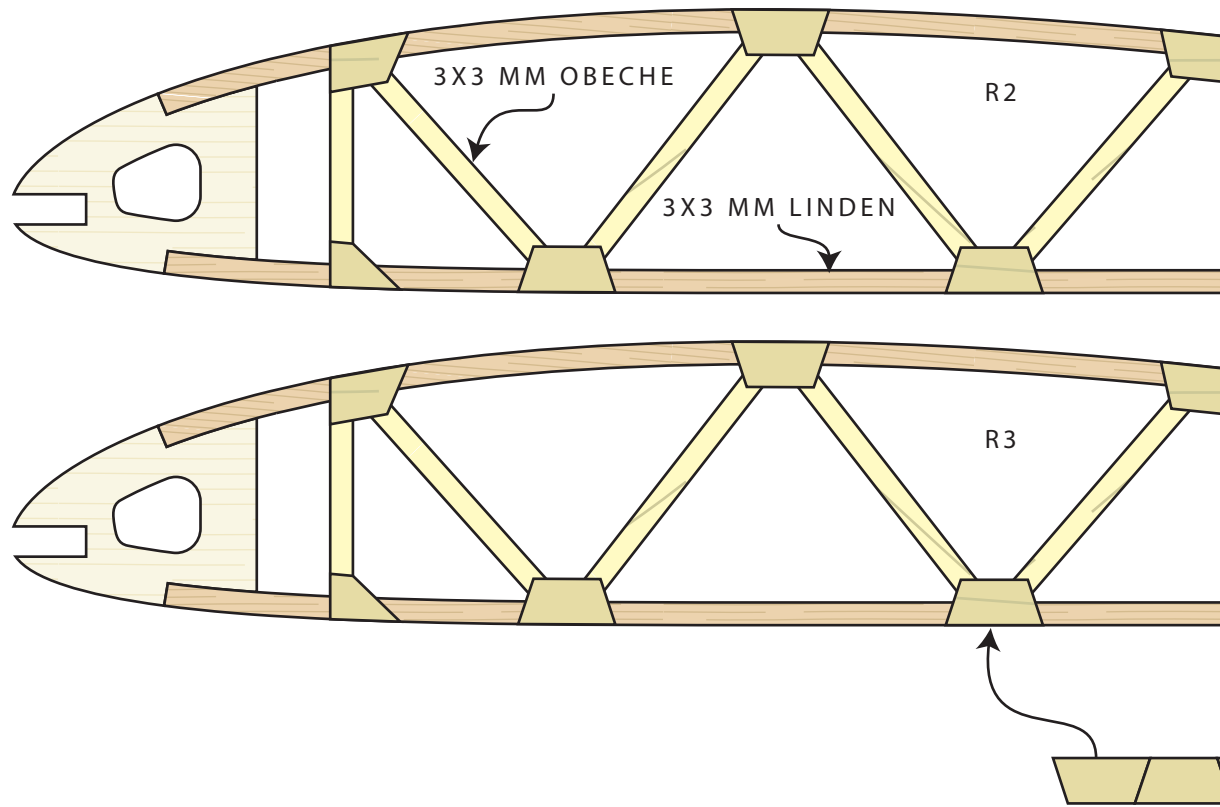



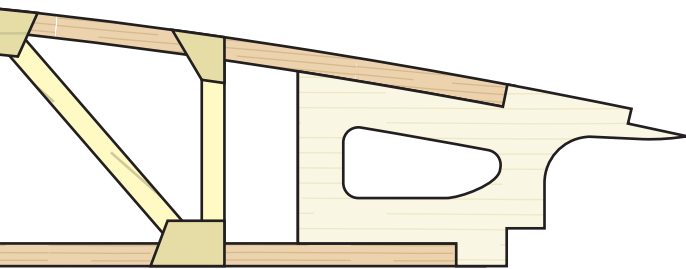
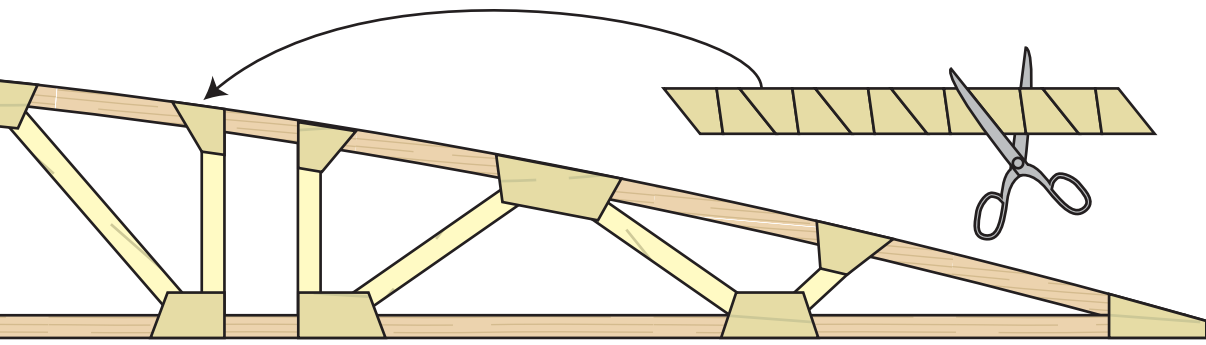

MAKE THE GUSSETS WITH A 0,8 MM PLY STRIPS

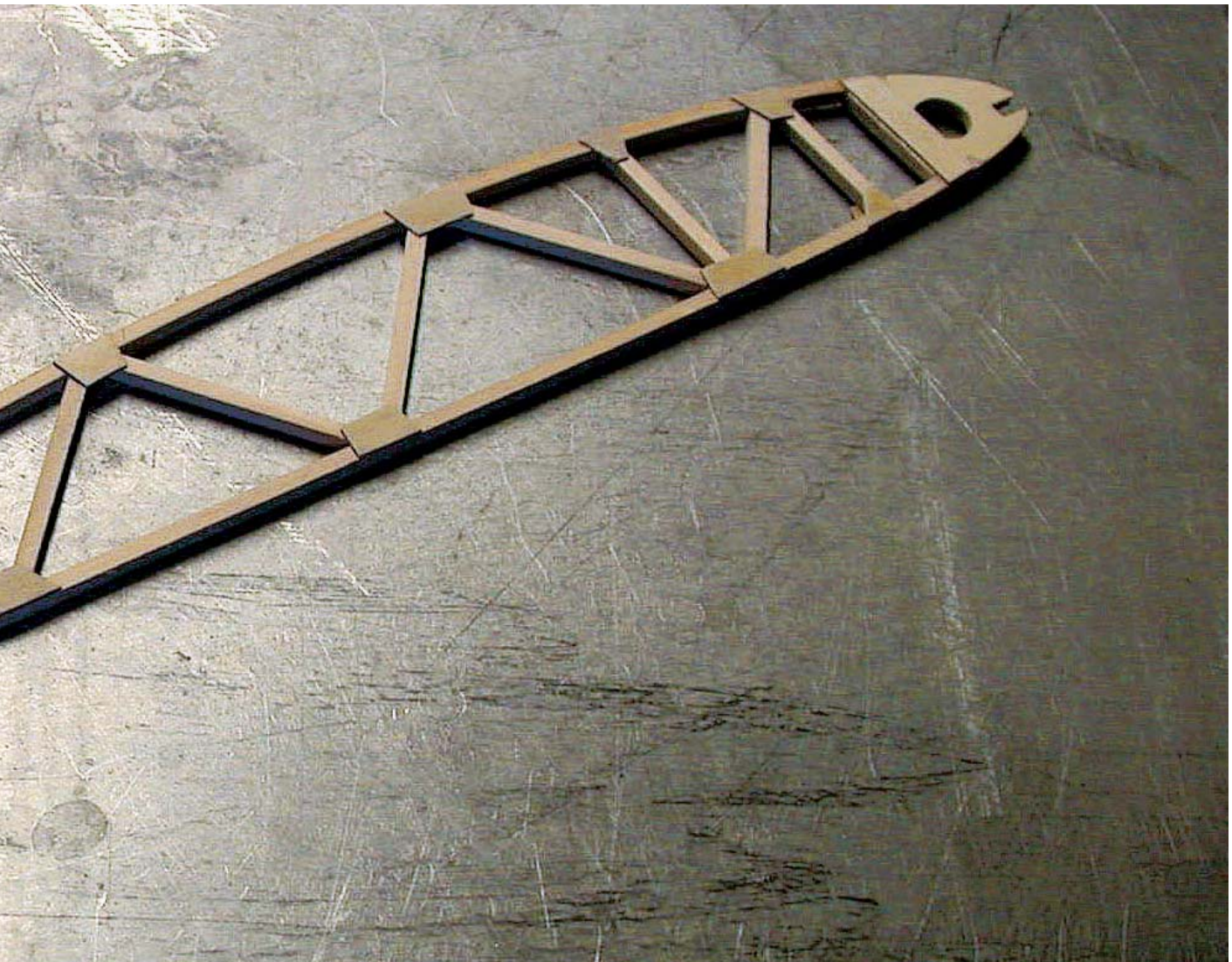
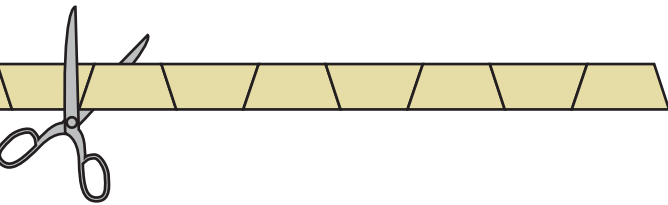

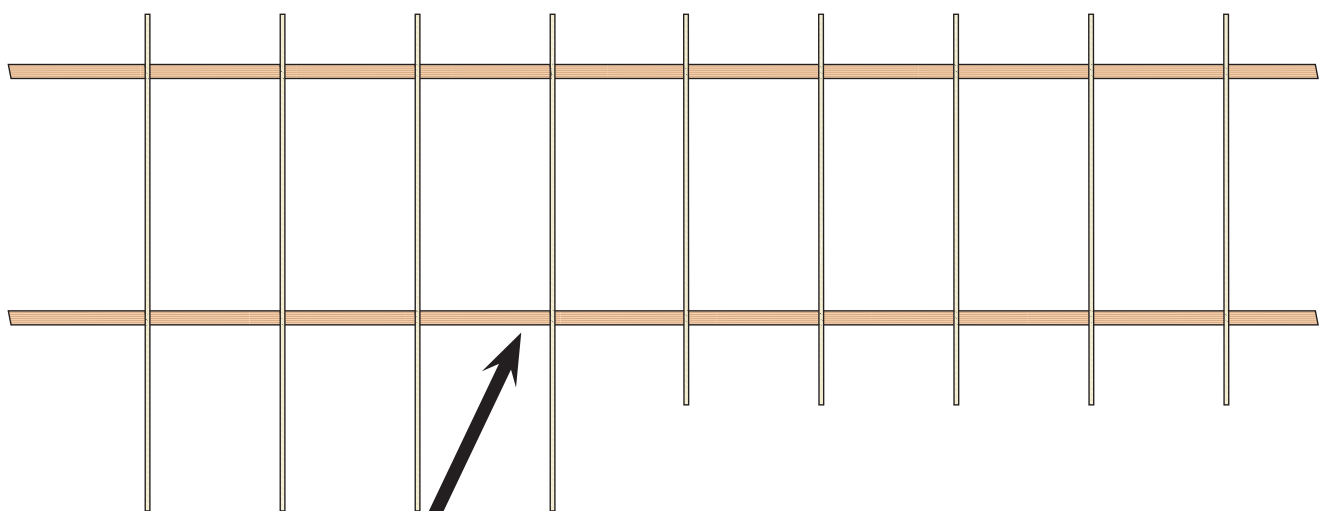
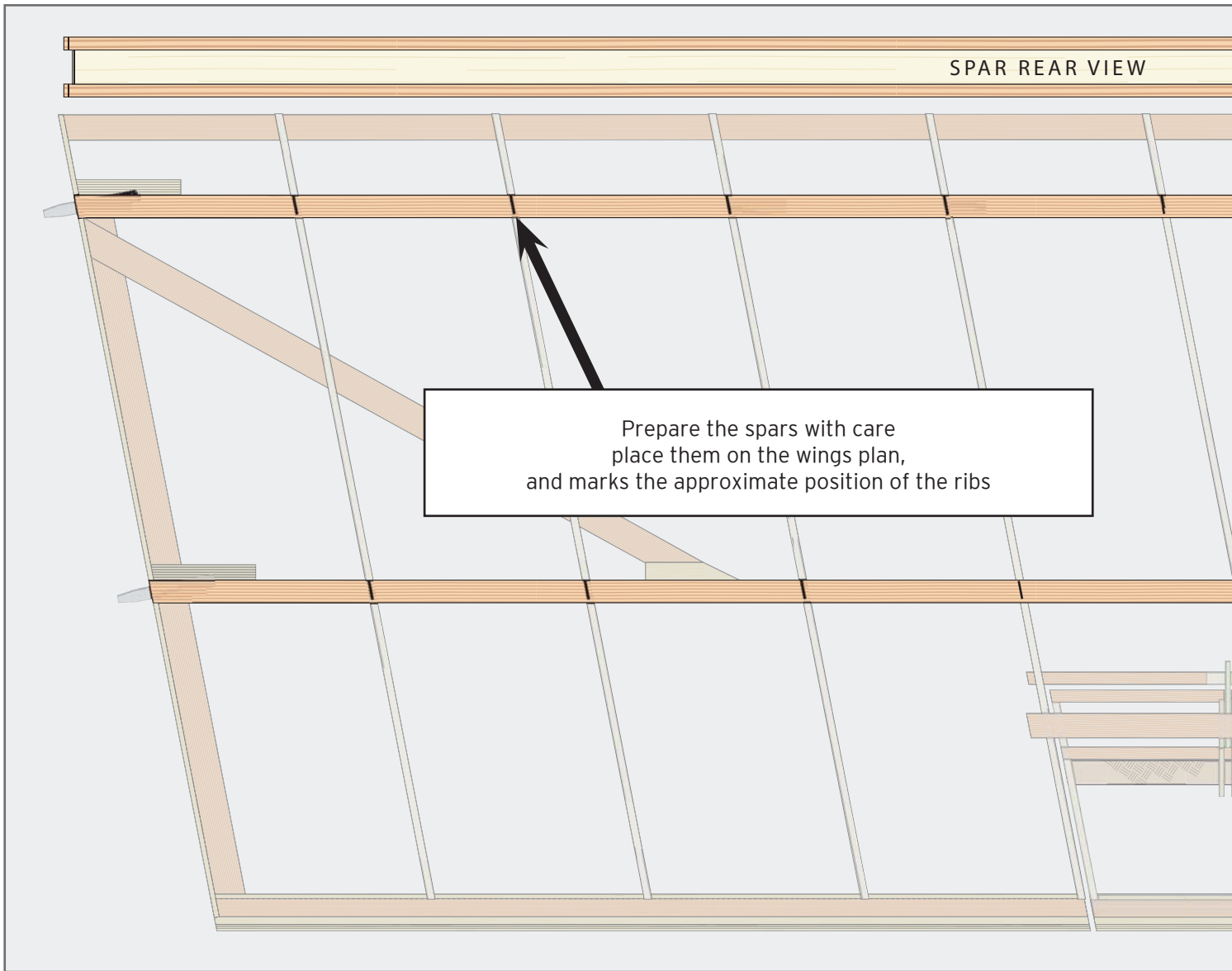

Insert the spars into the ribs without glue



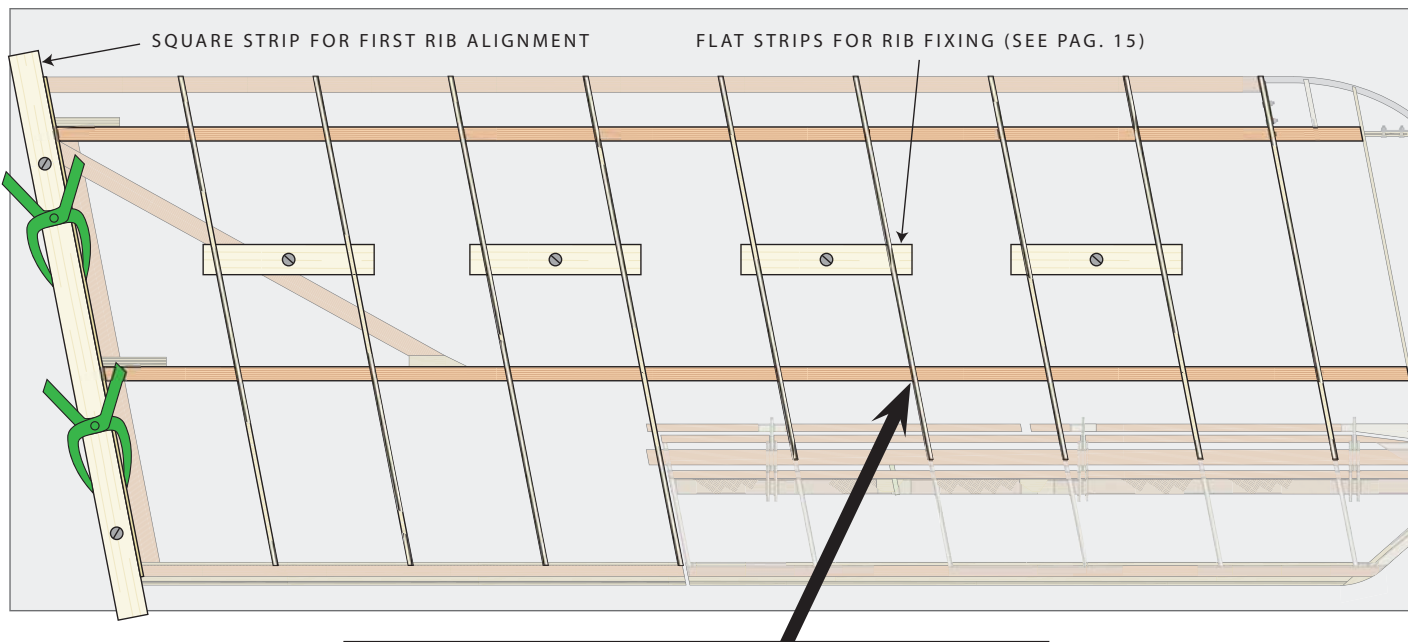
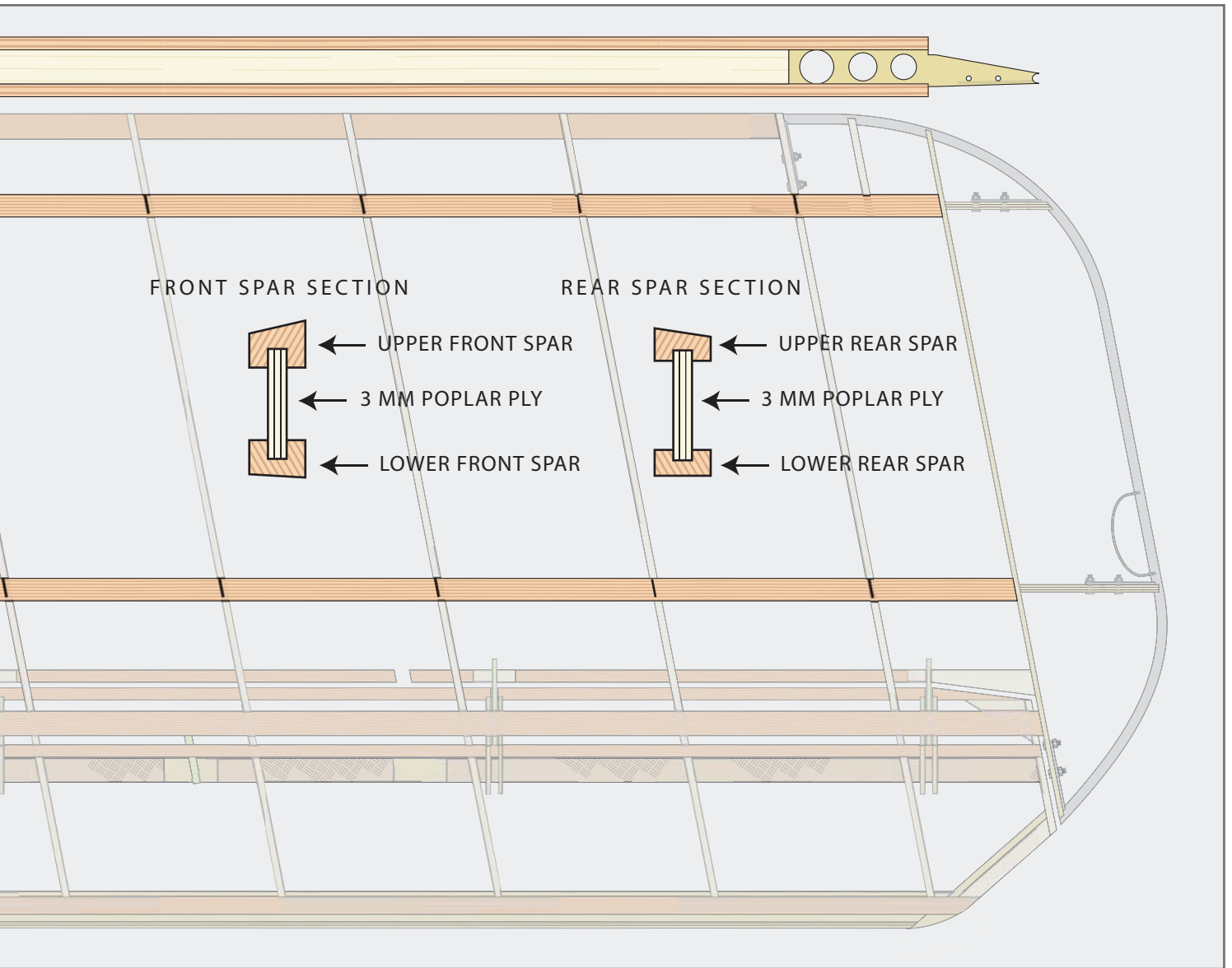

Put on the plan, align and fix the ribs,  
and glue with C. A.

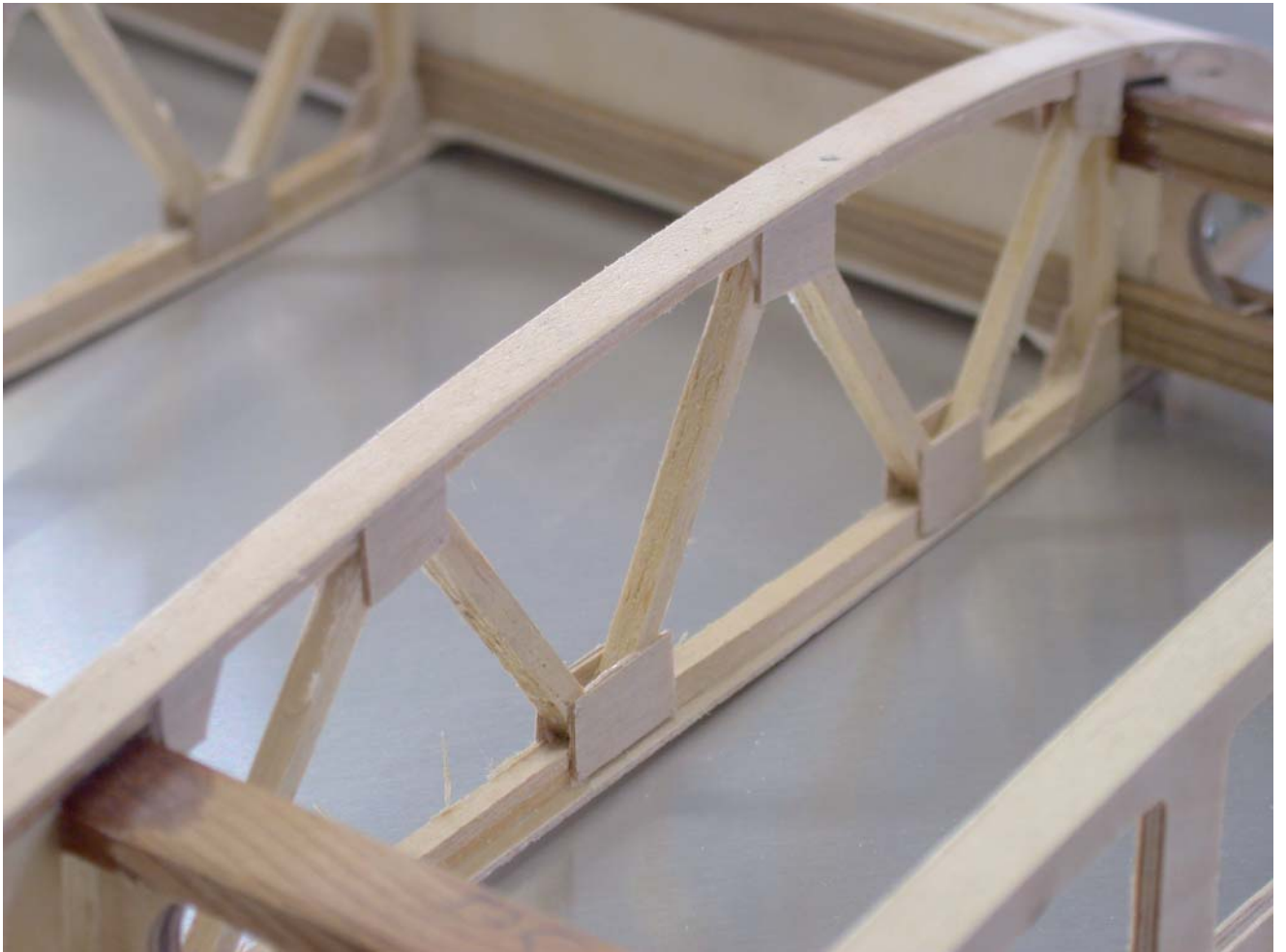
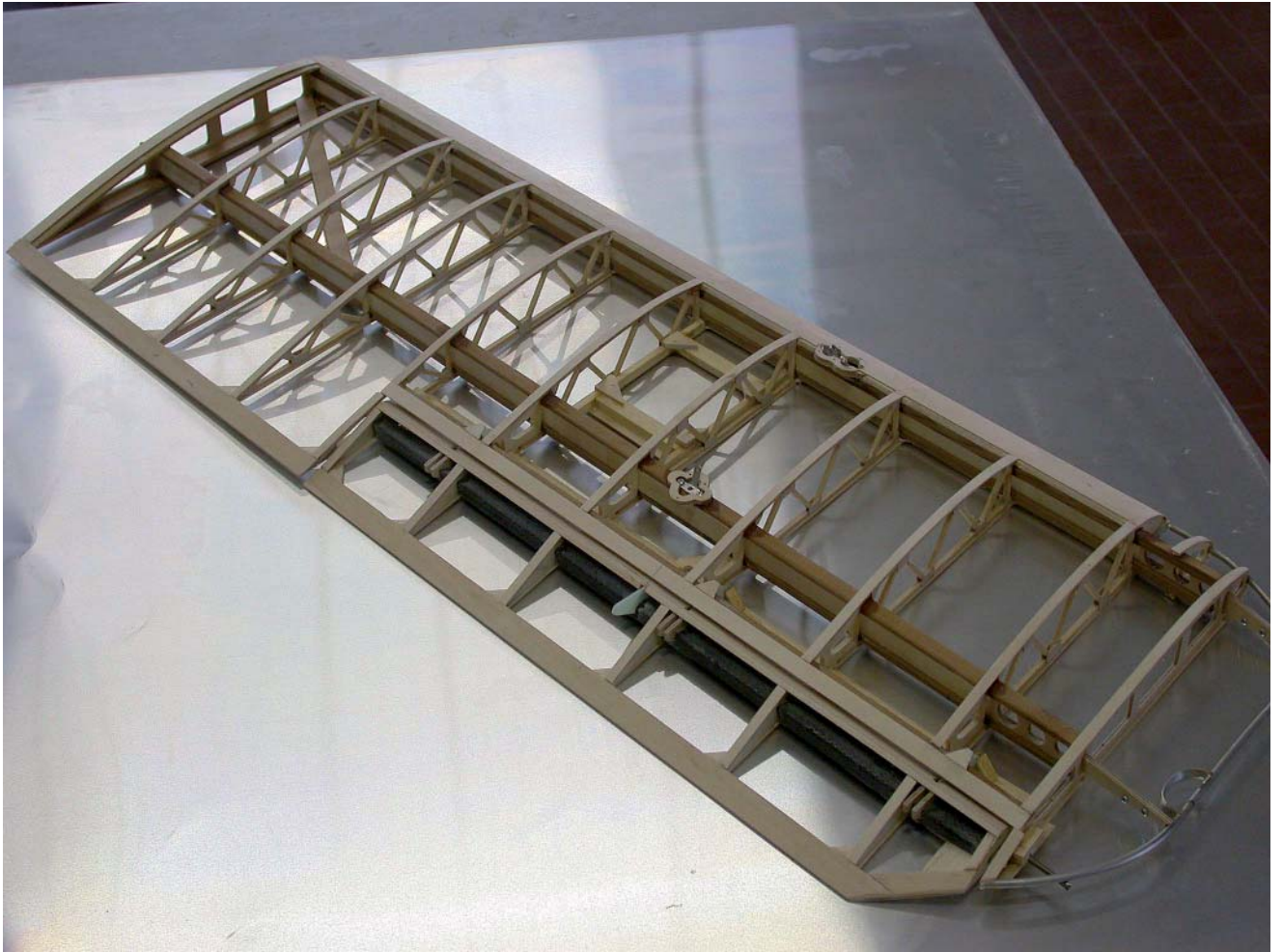



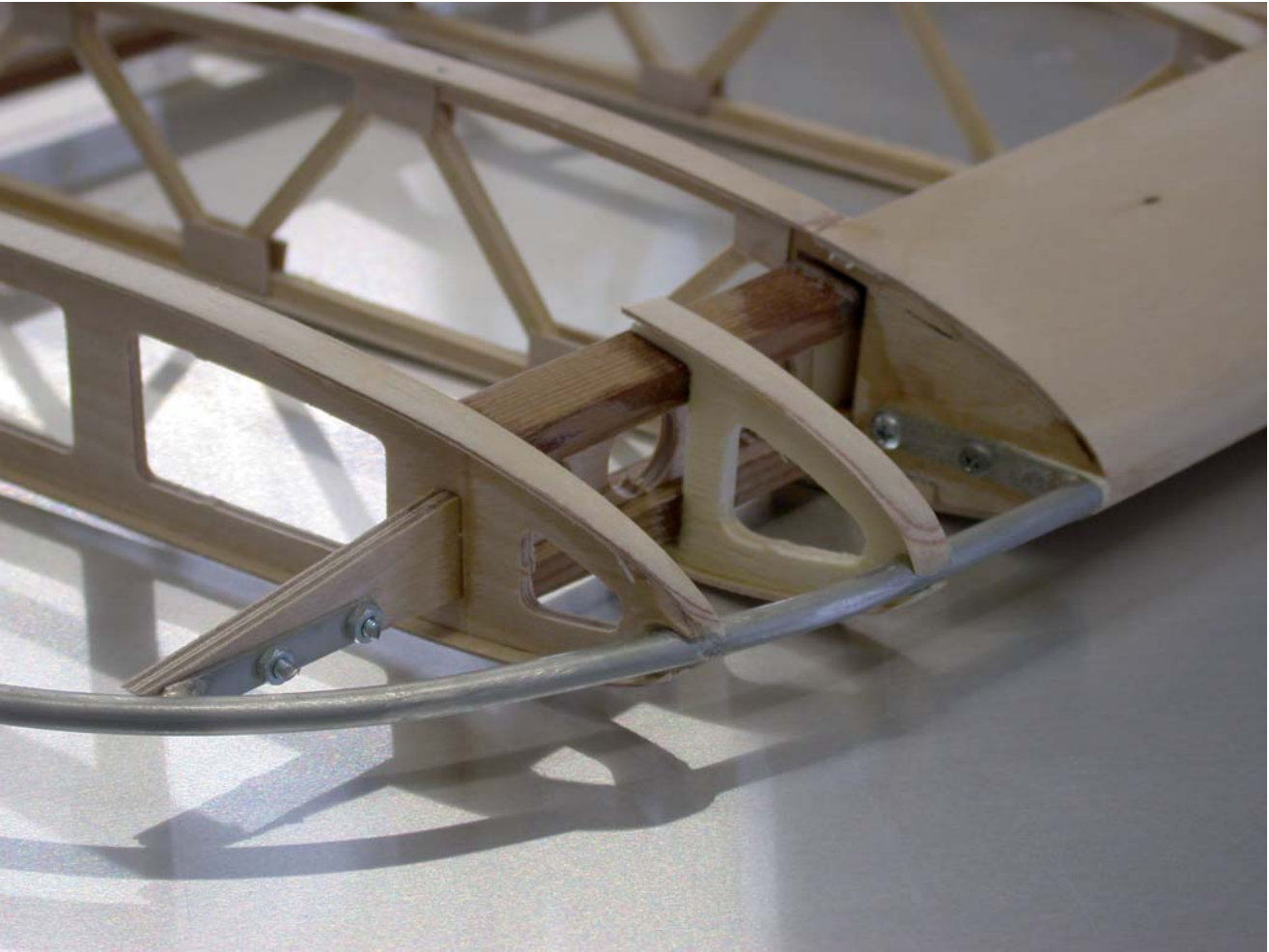





## CABLES ADJUSTING

Note: For a general control, is better to make this operation also before covering.

1. Adjust the cabana struts and cables as in photos at page 19, 20 and 21.

2. Link the lower wing cables and adjust the lower wing dihedral approx. at  $3^\circ$

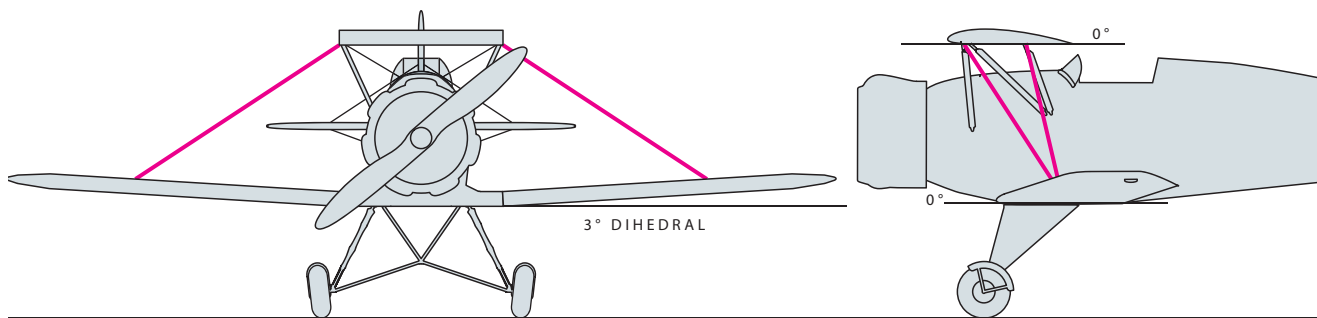
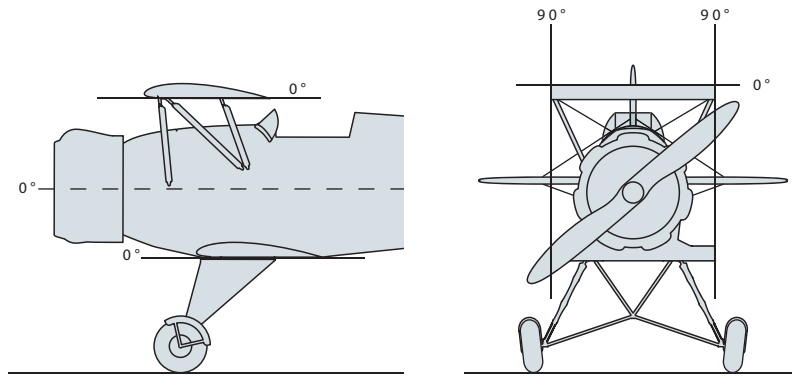

3. Insert the upper wing and connect the cable to the attachment of the front strut.

4. Insert the front strut between the wings, and regulate the cables tension and length. Measure the dihedral incidence at front spar.

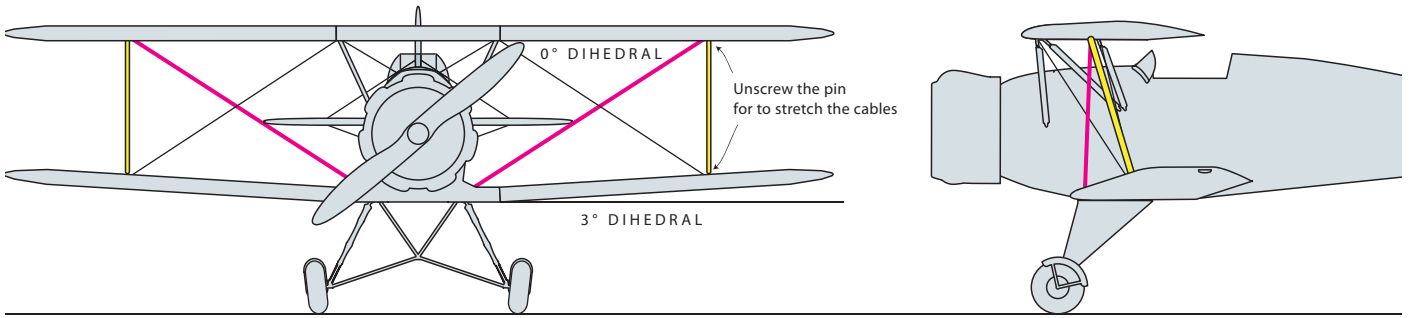



5. Connect the rear cable and the long cross cable.

6. Insert the rear strut and regulate incidence at wing end.

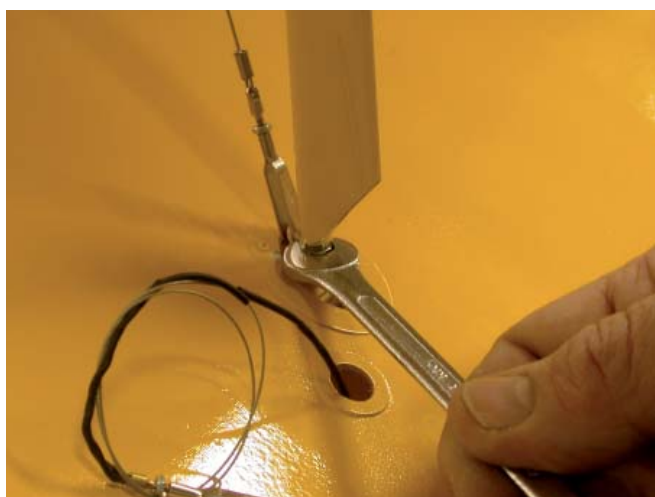
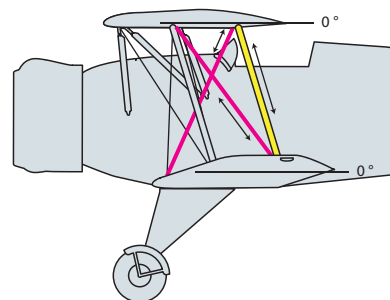
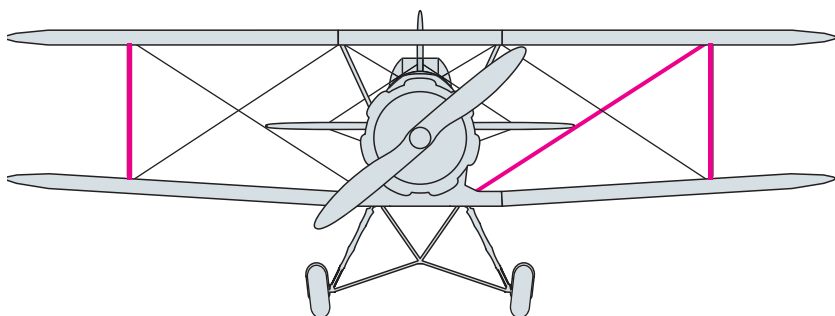

7. Connect the short cross cable.

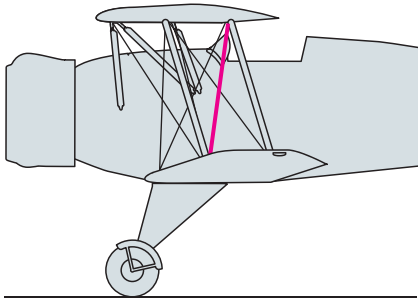

8. Control cable tension.

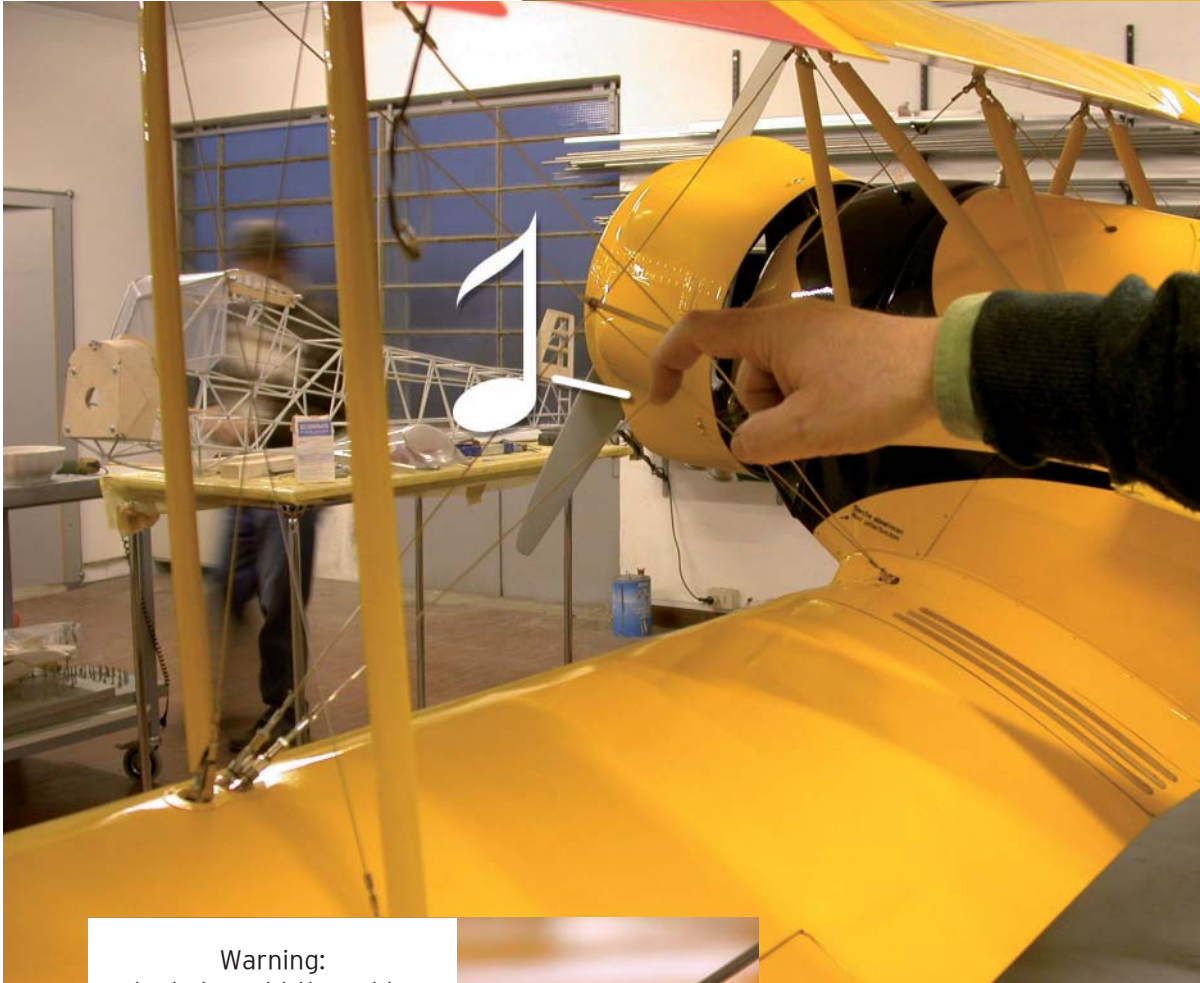

Warning:  
dont strenght the cables  
and dont fly  
without security rings!

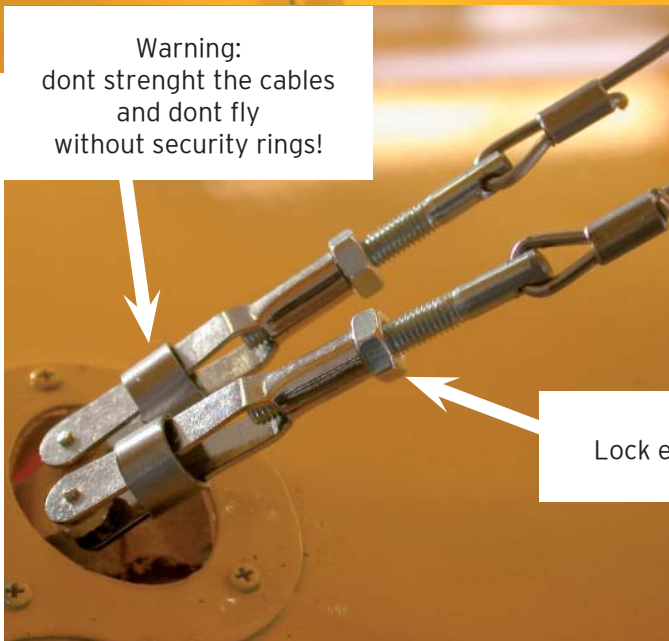

Lock every link with a nut for quick mounting.



9. Connect and regulate the aileron cables.

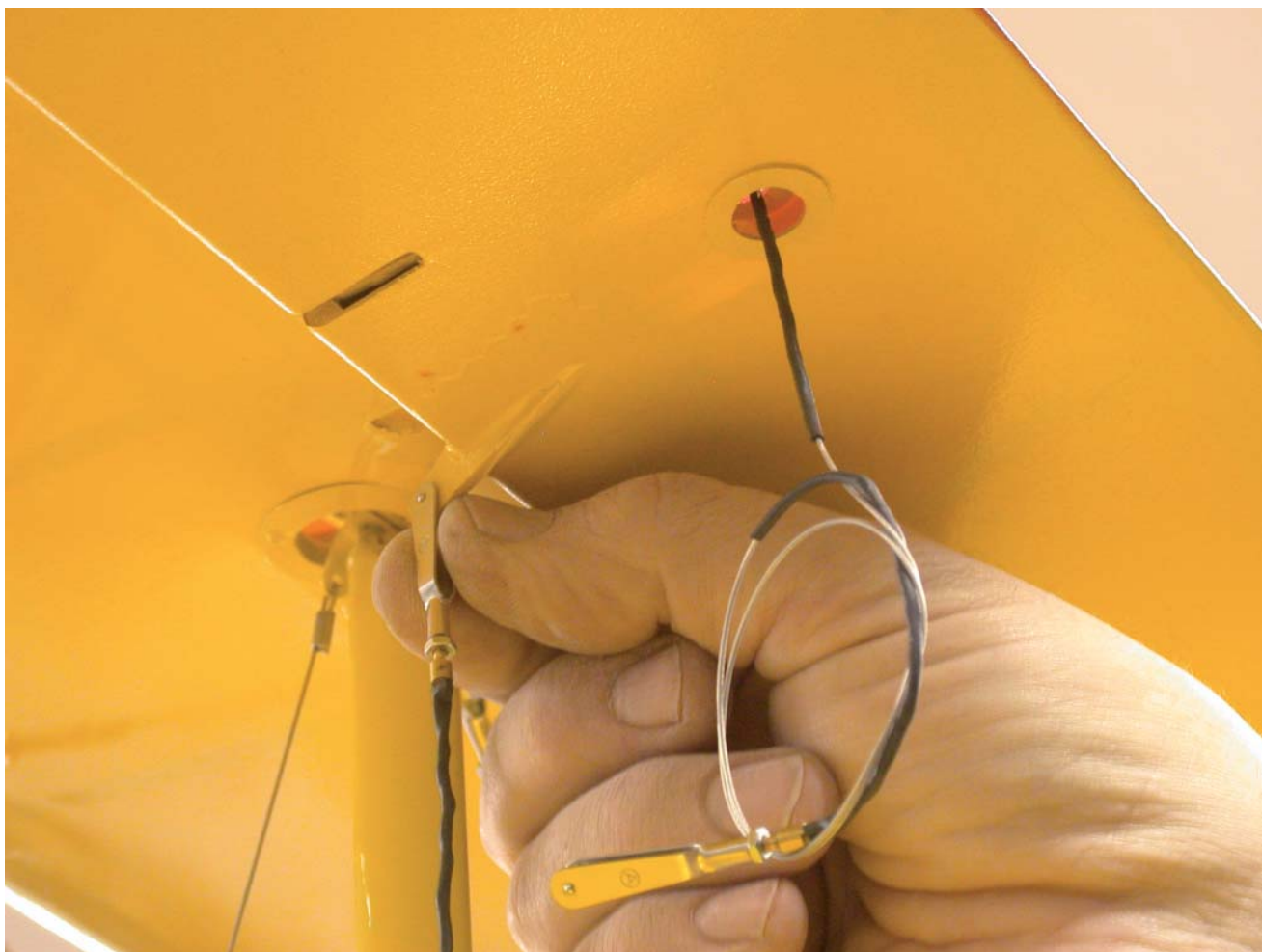

**BÜCKER BU133**  
**"JUNGMEISTER"**  
**1/3 SCALE**

Wingspan: 220 cm (86,6 in)  
Length: 192,3 cm (75,7 in) without prop  
Wing area: 120,8 sq/dm (13 sq/ft)  
Weight: 10/15 Kg (22/33 lb)  
Engine: 50/100 cc two stroke - 70/200 cc four stroke radial

Projected and drawn by Paolo Severin - September 2009

[www.paoloseverin.it](http://www.paoloseverin.it)

Paolo Severin srl  
Via Decorati al Valor Civile 57a  
35142 Padova - Italy  
Laboratorio: Via Monfalcone 11 - Padova

Tel. 049 8800329 - Fax 049 8800354

email: [paolo.severin@pallino.it](mailto:paolo.severin@pallino.it)